

Upgrade plan of SuperKEKB RF system in Long Shutdown 2

Takaaki Yamaguchi
(on behalf of SuperKEKB RF group)

Contents

1. Present status of SuperKEKB RF system
2. Upgrade plan in Long Shutdown 2 (LS2)
3. Summary

Present status of SuperKEKB RF system

SuperKEKB RF system

- 30 RF stations in total:
 - ✓ LER (e^+)
 - 16 stations for 22 normal-conducting (ARES) cavities
 - ✓ HER (e^-)
 - 6 stations for 8 normal-conducting cavities
 - 8 stations for 8 superconducting cavities
- RF station = Cavity(-ies) + Klystron + low-level RF (LLRF)
 - ✓ 1:1 configuration: a cavity driven by a klystron
 - ✓ 1:2 configuration: two cavities driven by a klystron

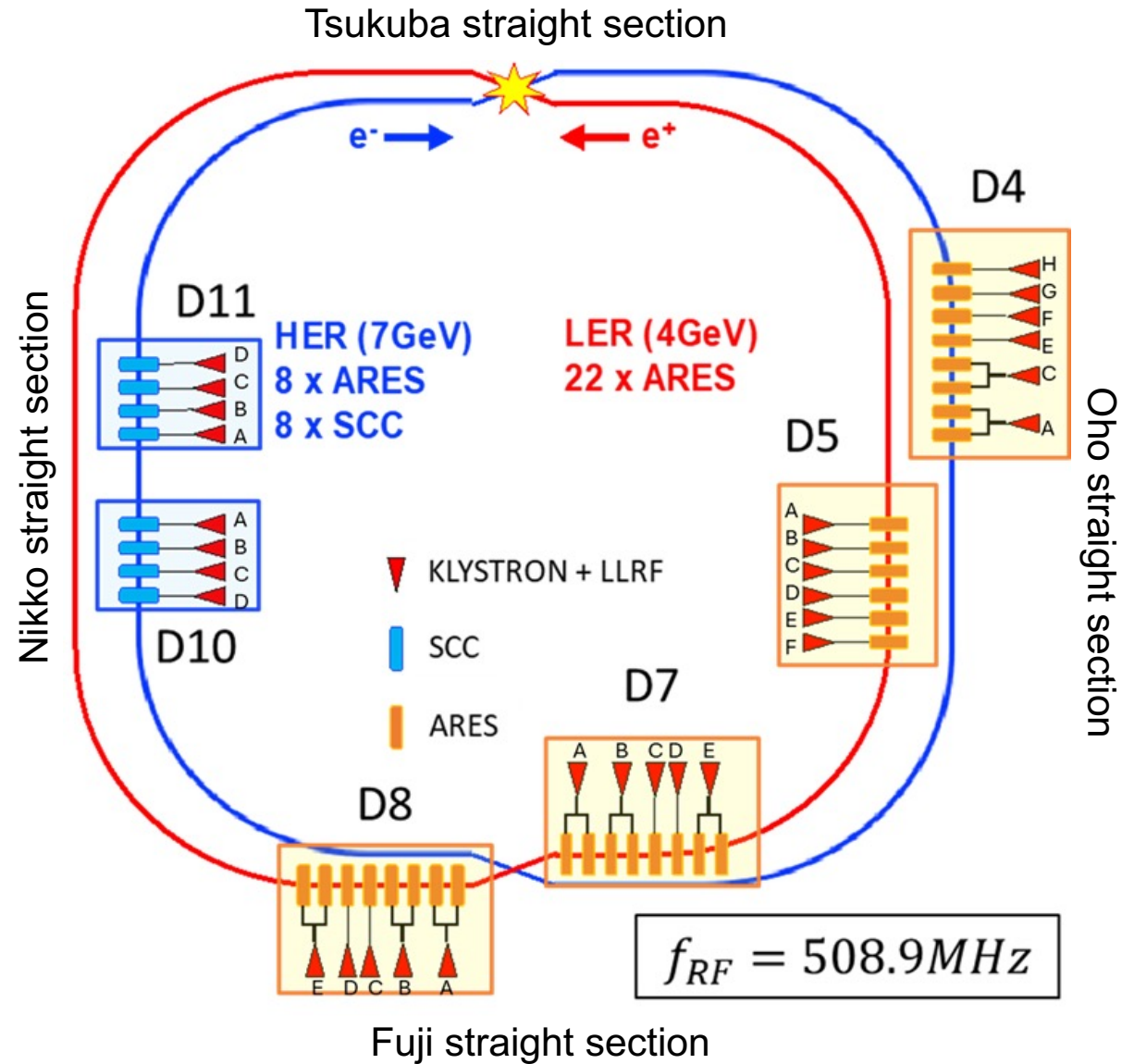

Present distribution of RF stations

RF-related parameters

Parameter	KEKB (achieved)			
	HER		LER	
Energy (GeV)	8.0		3.5	
Beam current (A)	1.4		2	
Number of bunches	1585		1585	
Bunch length (mm)	6–7		6–7	
Total beam power (MW)	~5.0		~3.5	
Total RF voltage (MV)	15.0		8.0	
Cavity type	ARES		SCC	ARES
Klystron : cavities	1:2	1:1	1:1	1:2
Number of cavities	10	2	8	20
RF voltage (MV/cav.)	0.5		1.5	0.5
Beam power (kW/cav.)	200	550	400	200

SuperKEKB (design)			
HER		LER	
7		4	
2.6		3.6	
2500		2500	
5		6	
8.0		8.3	
15.8		9.4	
ARES	SCC	ARES	
1:1	1:1	1:2	1:1
8	8	8	14
0.5	1.5	0.5	
600	400	200	600

SuperKEKB (achieved)				
HER			LER	
7			4	
1.35			1.7	
2346			2346	
~6			~6	
~3.6			~3.3	
14.2			9.12	
ARES		SCC	ARES	
1:2	1:1	1:1	1:2	1:1
4	4	8	8	14
0.40	0.45	1.35	0.40	0.45
200	220	300	180	250

- The RF system of KEBK was reused for SuperKEKB with reinforcement of high-power sources, etc.
- The large design beam currents are major issues for the RF system.

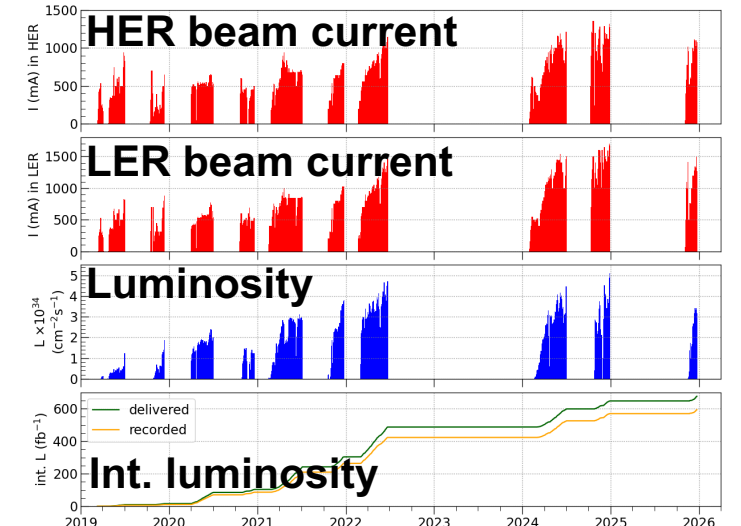

Accelerating cavities

- In the SuperKEKB main ring, two types of RF cavities have been used.

- Normal-conducting ARES cavity**

- ARES: Accelerator Resonantly-coupled with Energy Storage
- Three-coupled-cavity system
- Storing large energy in the energy-storage cavity, coupled-bunch instabilities caused by acc. mode are suppressed.

	ARES	SC
freq.	508.876 MHz	
R/Q	15 Ω ($\pi/2$ mode)	93 Ω
Vc	0.5 MV/cav.	1.3–1.5 MV/cav.

- Single-cell superconducting cavity (SCC)**

- Used only in HER with ARES cavities to supply large RF voltage.
- Higher-order modes (HOMs) are heavily damped by ferrite dampers in the large-bore beam pipes.
 - LBP: $\phi 300$ mm
 - SBP: $\phi 220$ mm

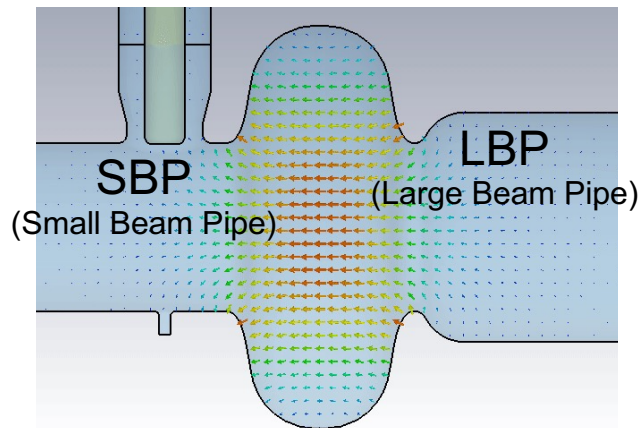
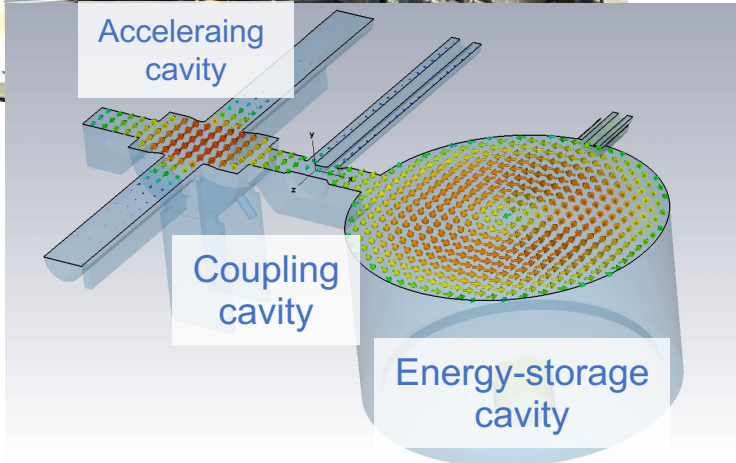
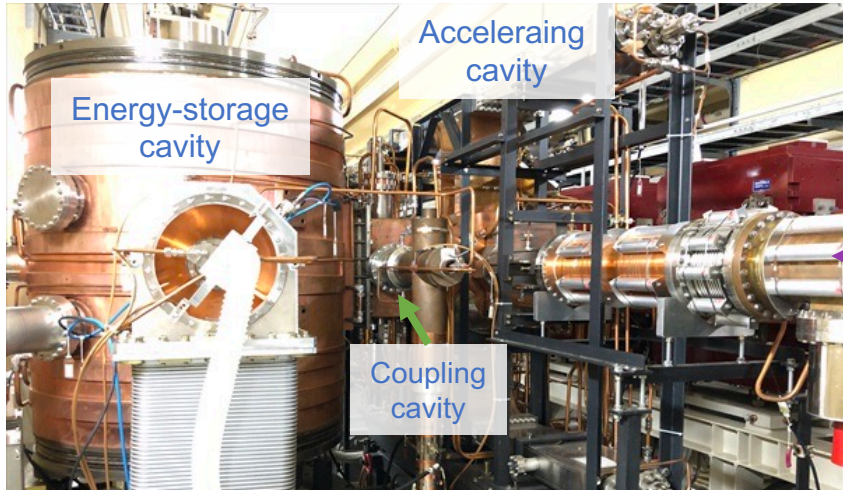

Beam

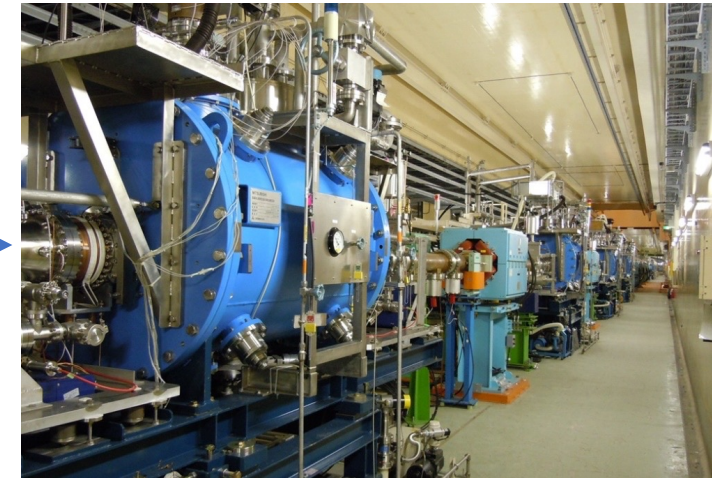

Ferrite dampers

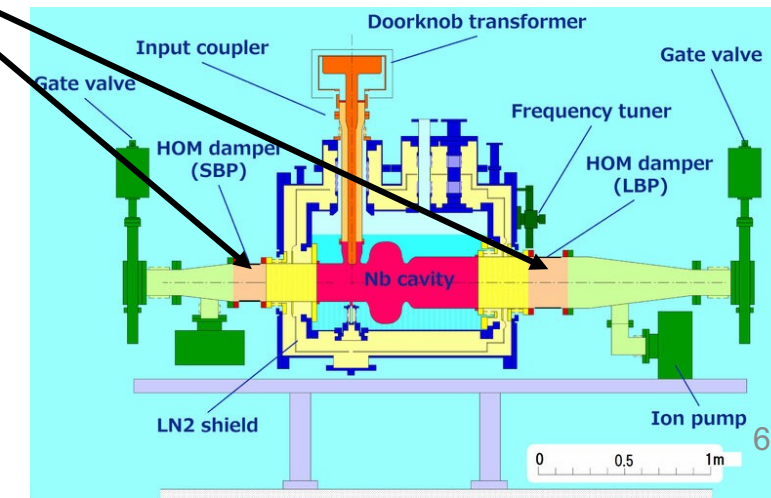

Low-level RF control system (LLRF)

- During the upgrade to SuperKEKB, some analog LLRFs for ARESs were replaced to digital ones.
- We still use analog LLRFs.



Analog LLRF

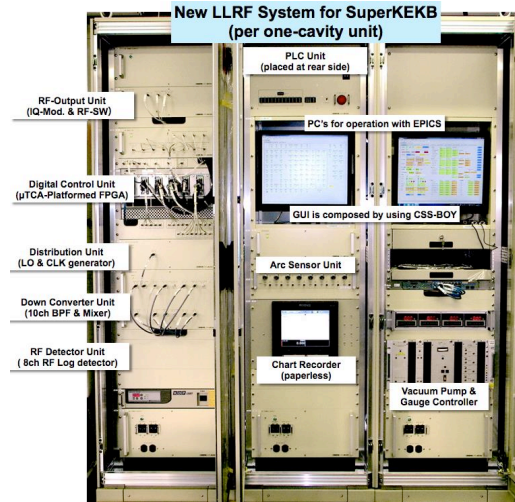

Digital LLRF

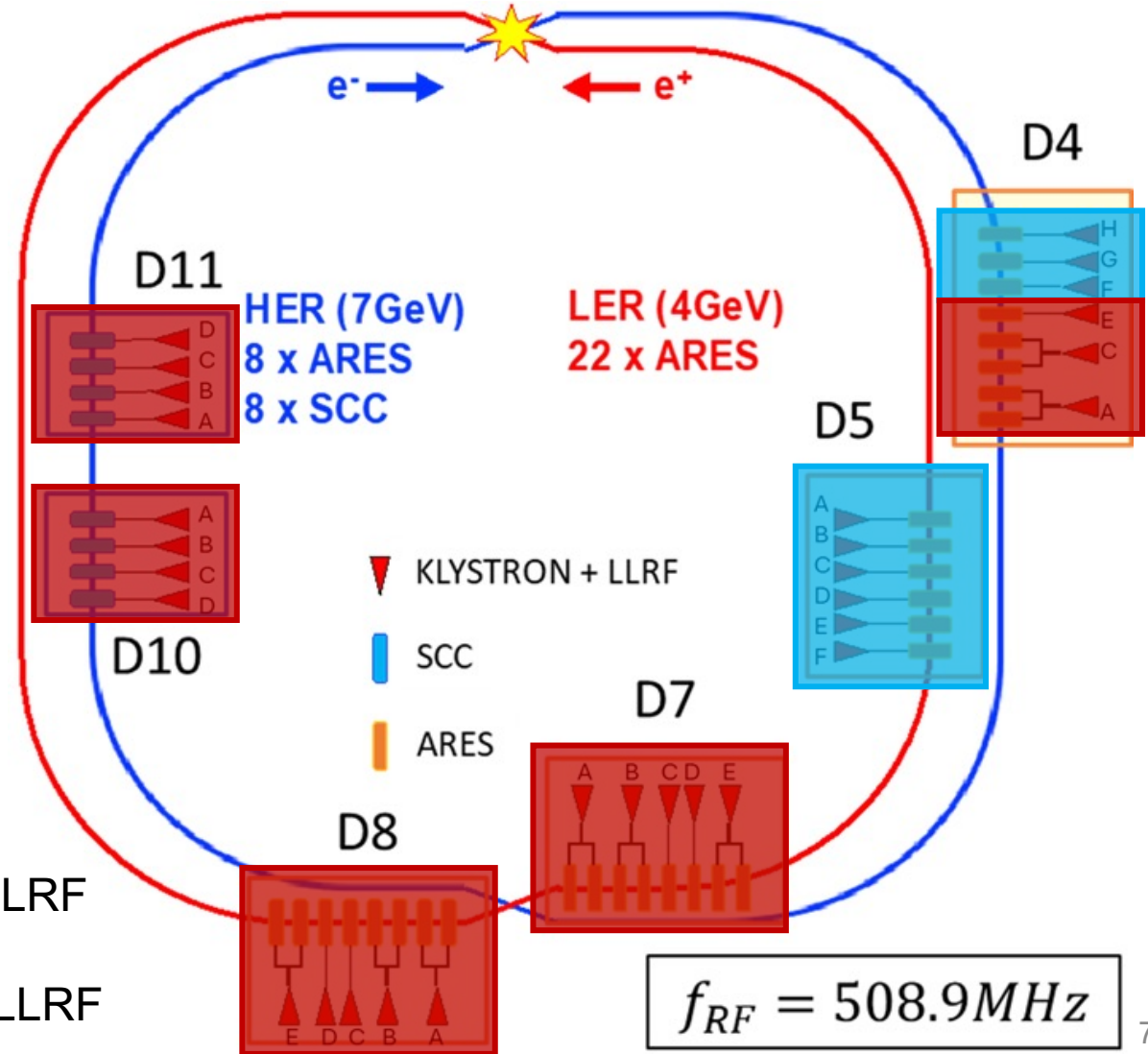

Upgrade plan in LS2

Beam current limit caused by RF system

- In the present RF system, the following factors limit the beam current:

✓ Delivered RF power to beam

✓ HOM power in SCCs

Upgrade plan in LS2

→ Increase klystrons

→ Reinforce the HOM dampers

Upgrade on high-power system

Estimation of delivered power to beam (LER)

- Limiting factors of delivered power:
 - ✓ Practical klystron output power: ~800 kW (considering linearity)
 - ✓ Input power to the SCC coupler: ~400 kW (empirical limit)
- Optimizing the beam loading ratio (phase difference) between 1:1 ARESs and 1:2 ARESs, **the design beam current can be stored in LER without any upgrade in RF system.**

Without phase difference

- - - 1:1 ARES
- - - 1:2 ARES

With optimized phase difference

- 1:1 ARES
- 1:2 ARES

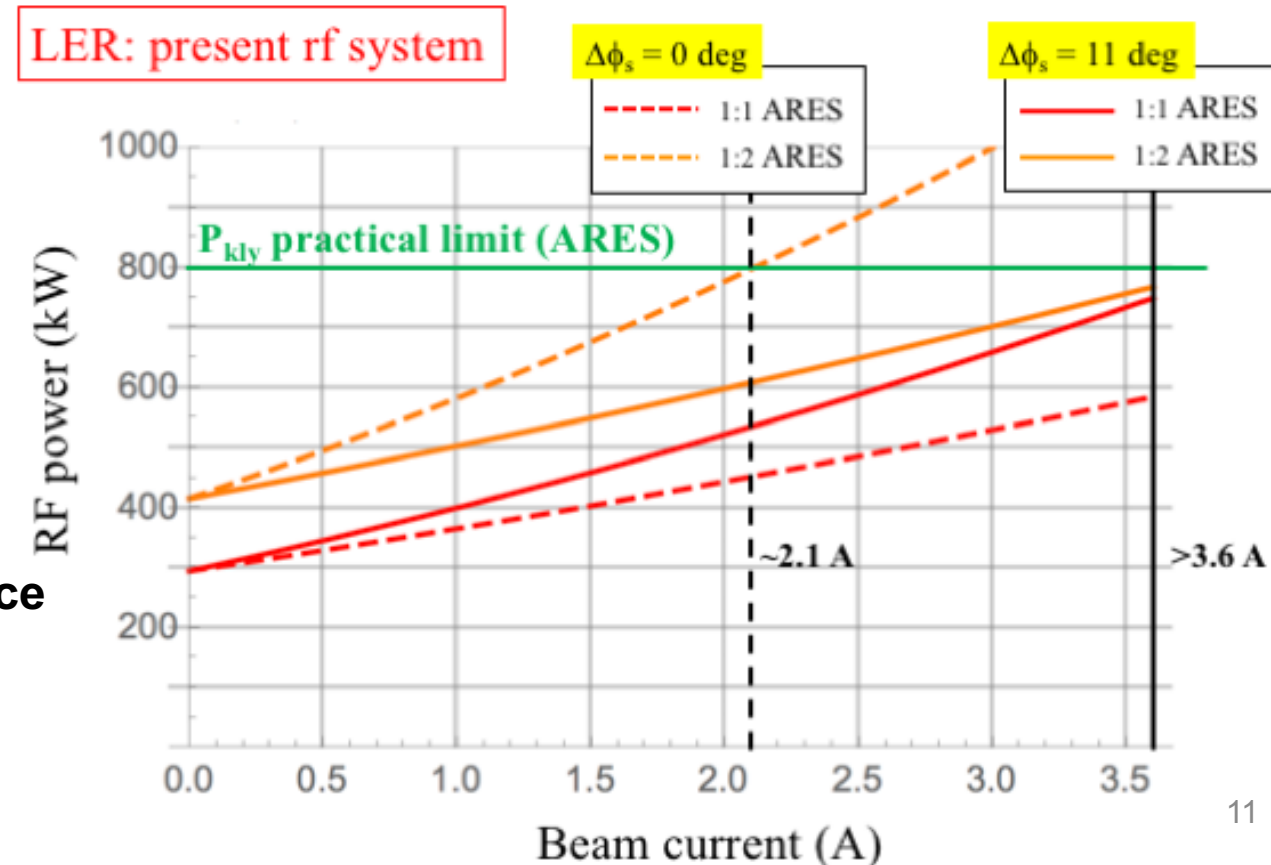

Estimation of delivered power to beam (HER)

- Limiting factor of delivered power
 - ✓ Practical klystron output power: ~800 kW (considering linearity)
 - ✓ Input power to the SCC coupler: ~400 kW (empirical limit)
- In HER, the present RF system cannot reach the design beam current even though optimizing the loading ratio.

Without phase difference

- - - 1:1 ARES
- - - 1:2 ARES
- - - SCC

With optimized phase difference

- 1:1 ARES
- 1:2 ARES
- SCC

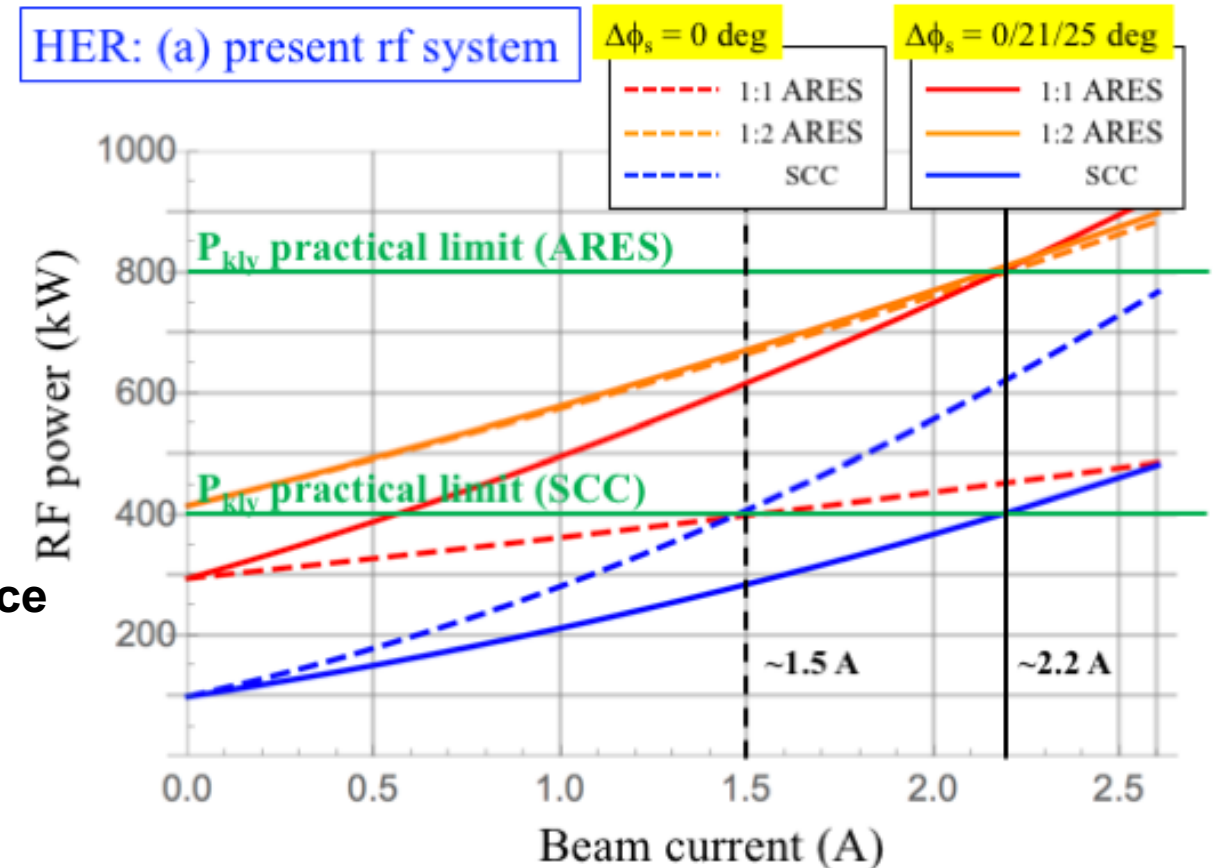

Estimation of delivered power to beam (HER)

- Limiting factor of delivered power
 - ✓ Practical klystron output power: ~800 kW (considering linearity)
 - ✓ Input power to the SCC coupler: ~400 kW (empirical limit)
- The design beam current in HER can be achieved **if we add two more klystrons.**

With optimized phase difference

— 1:1 ARES

— SCC

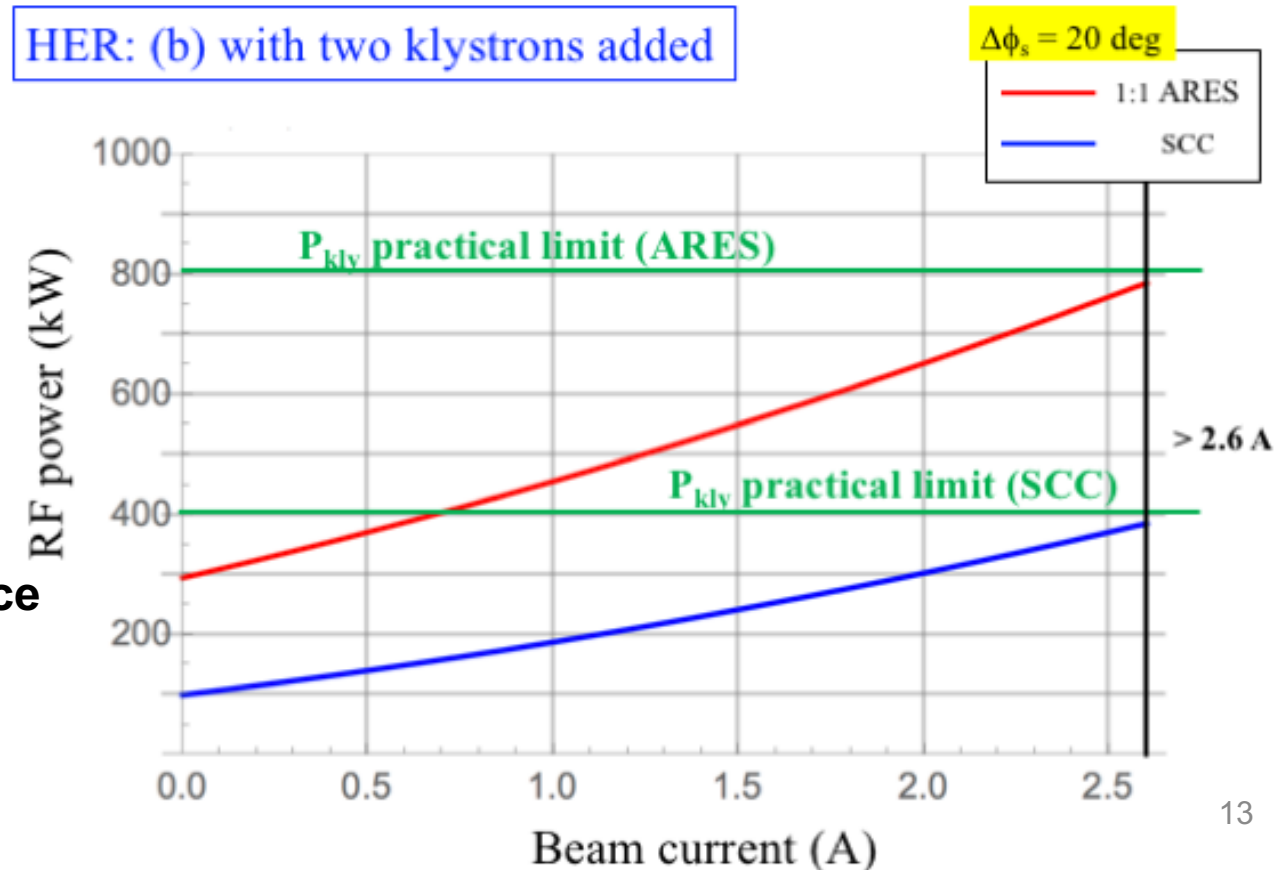

Plan to increase RF stations in D04

- We will replace the 1:2-configured stations in D04 to 1:1-configured ones.
- This upgrade requires:
 - ✓ Two klystrons
 - ✓ One HV power supply

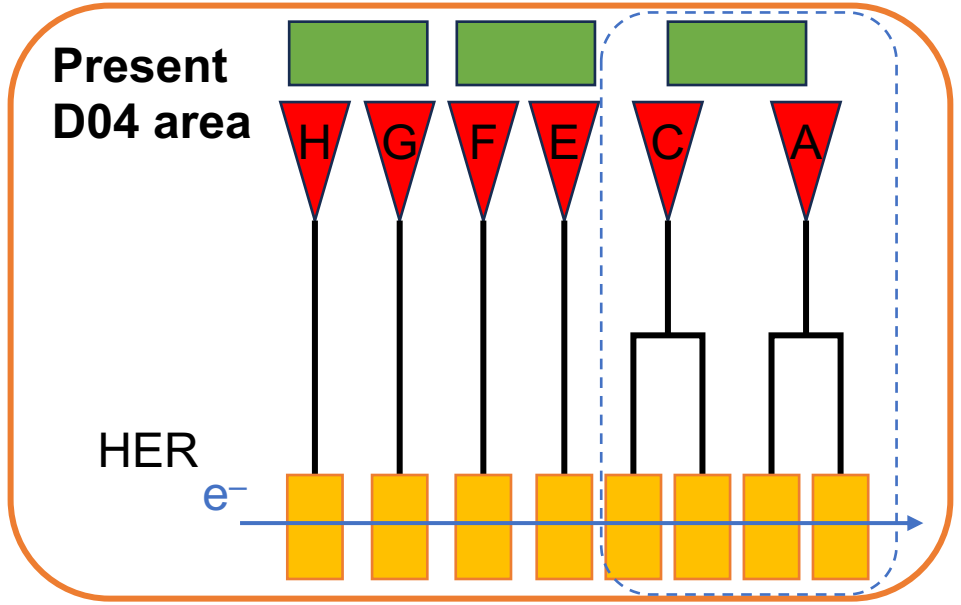
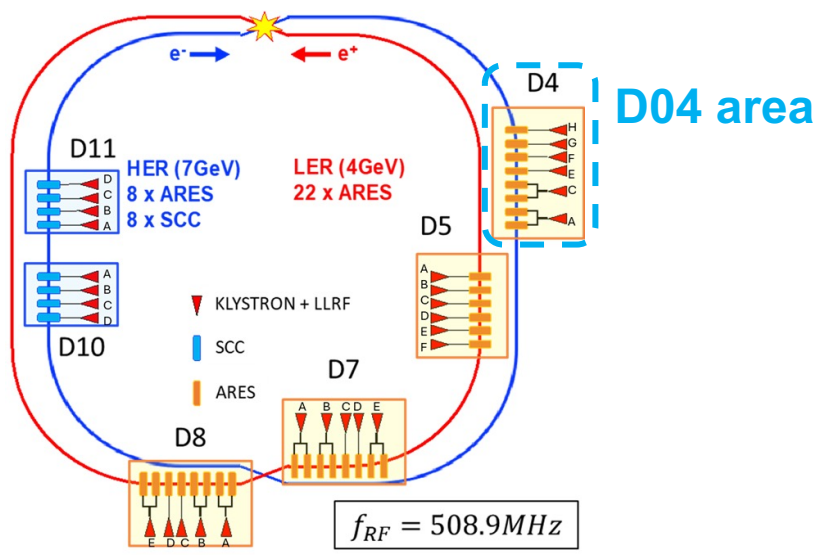

Upgrade

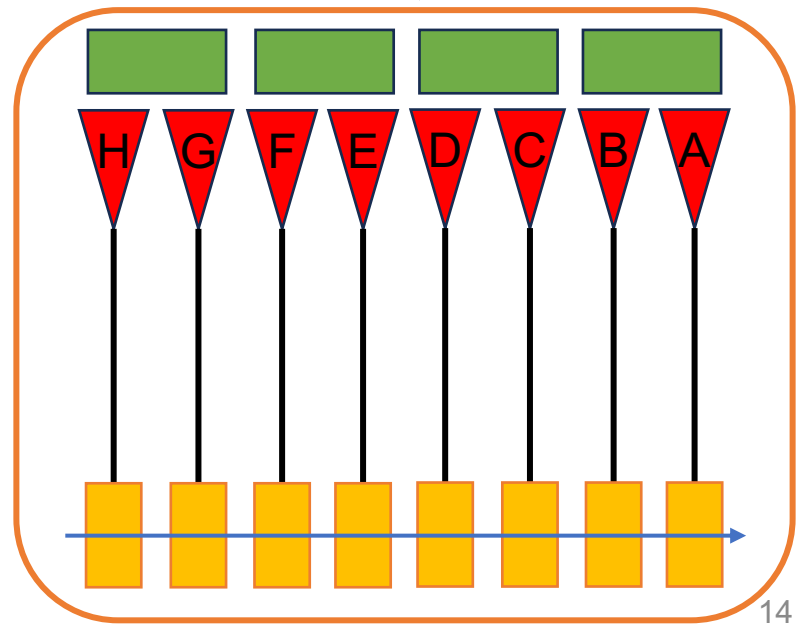

D4 power supply building (Feb 2026)

6 RF stations working to drive 8 ARES cavities

✓ Layout was already determined.

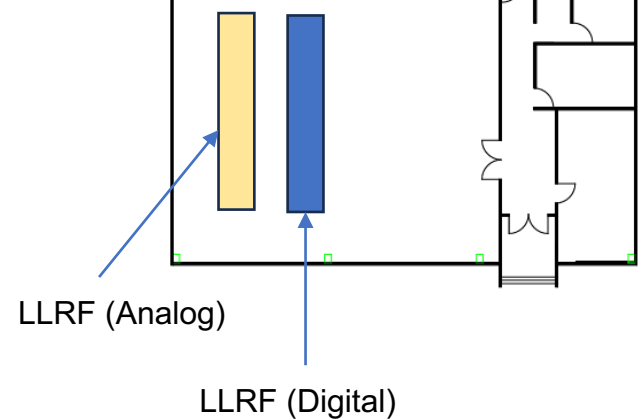
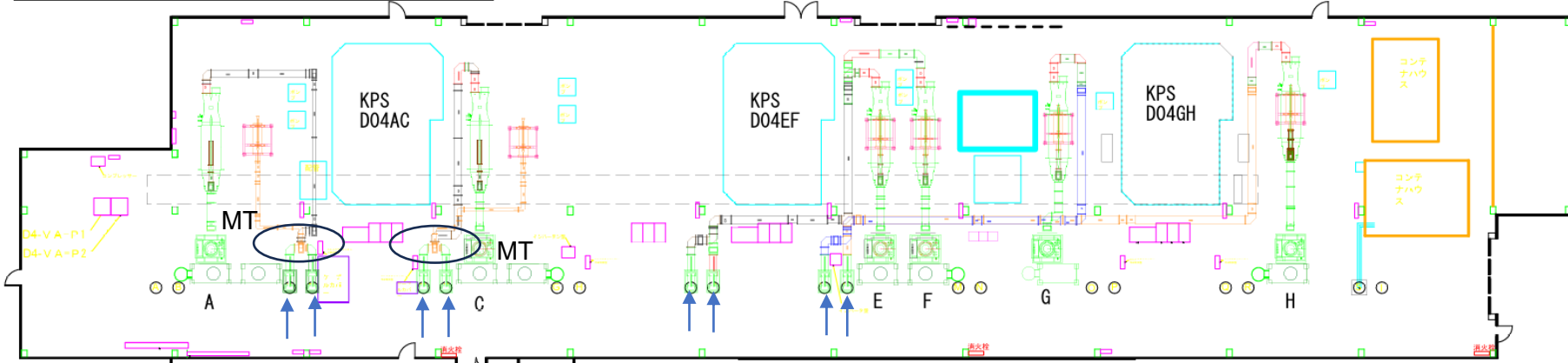

For LS-2 (20XX)

More two klystrons → 8 RF stations (8 ARES)

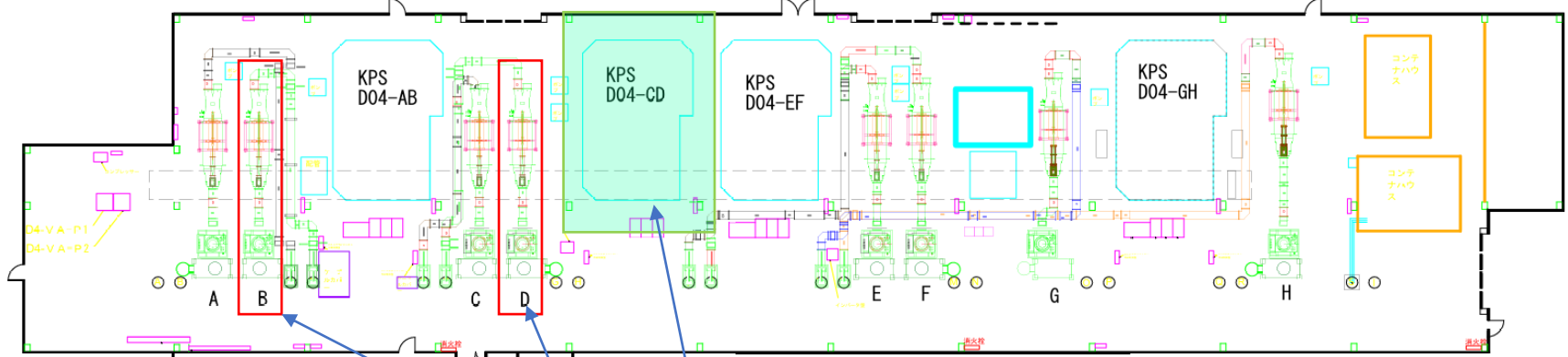

LLRF (Digital) -> Build a new Digital system

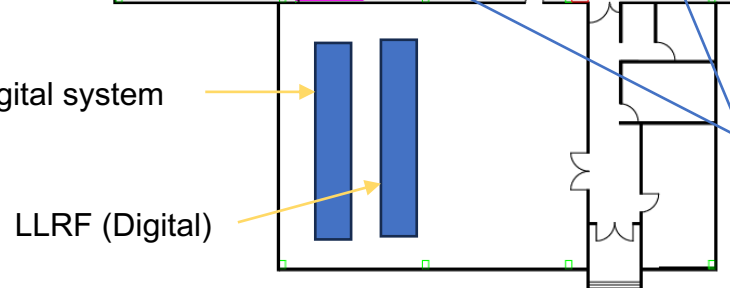

Build one type-A KPS (For D04-C and -D) (with wiring reconnection work)

Build two klystron and waveguide system (D04-B and -D) (with re-assembly work for waveguides to modify from 1:2 to 1:1)

*The Cooling system for HPRF was already built until 2016 (Phase1). -> Do not need any budget for it.

Replacement of LLRFs in D04 stations

- There are both digital and analog LLRFs in present D04 control room.
- To obtain the required space for new stations, we need to replace all the analog stations to digital ones.
 - ✓ **Totally five LLRF units will be installed.**
 - Two LLRFs for new stations
 - (Additional) three LLRFs for replacement of existing stations

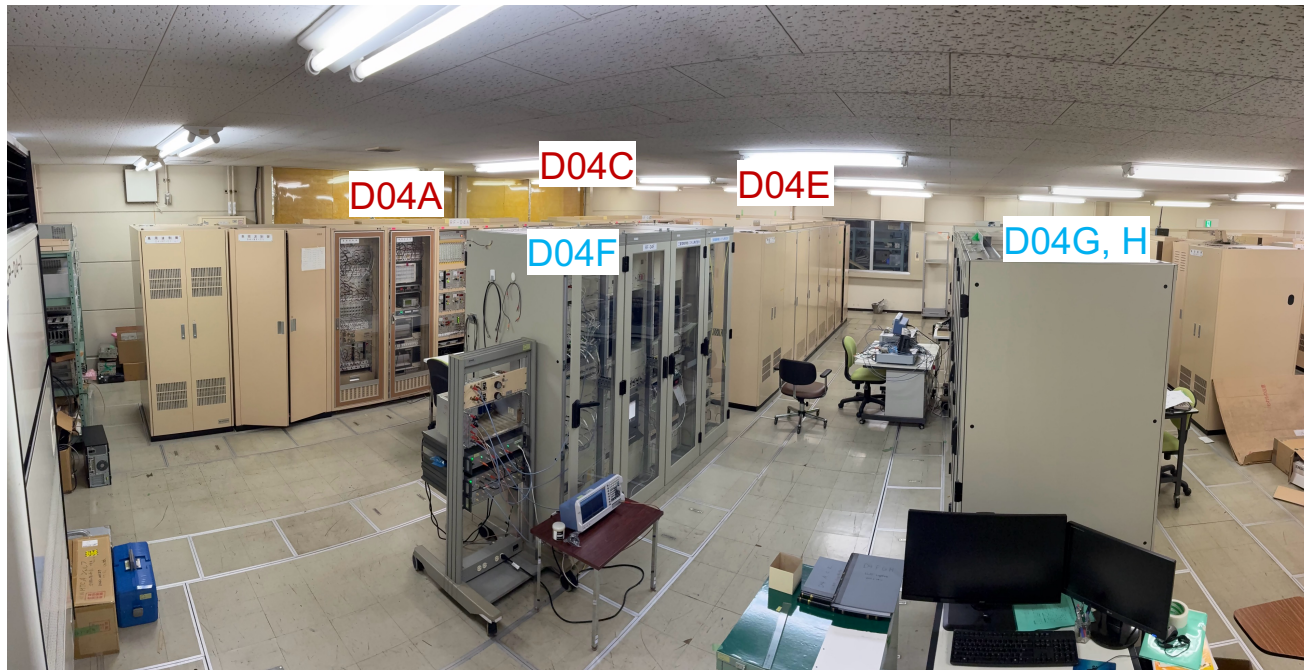
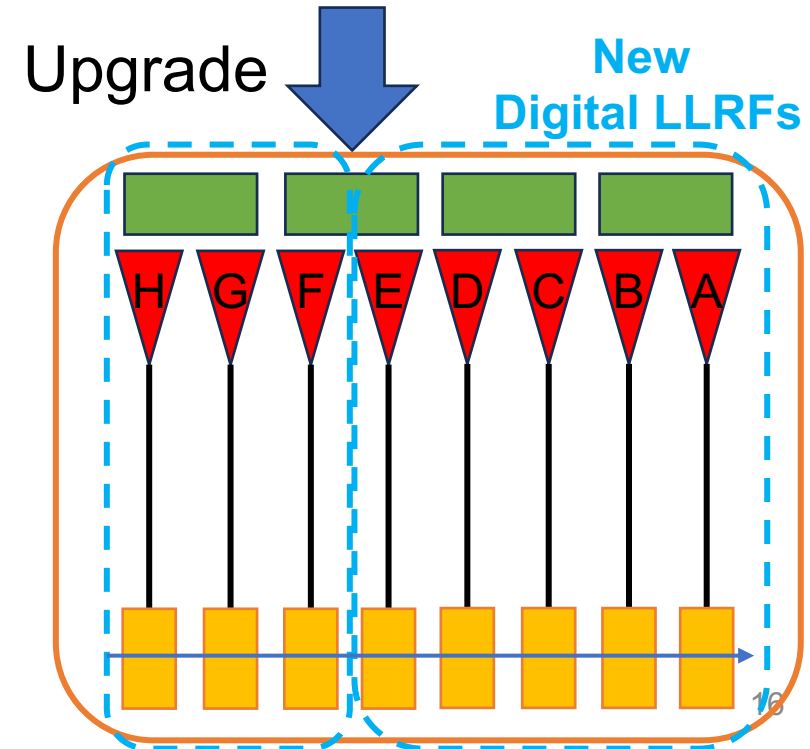
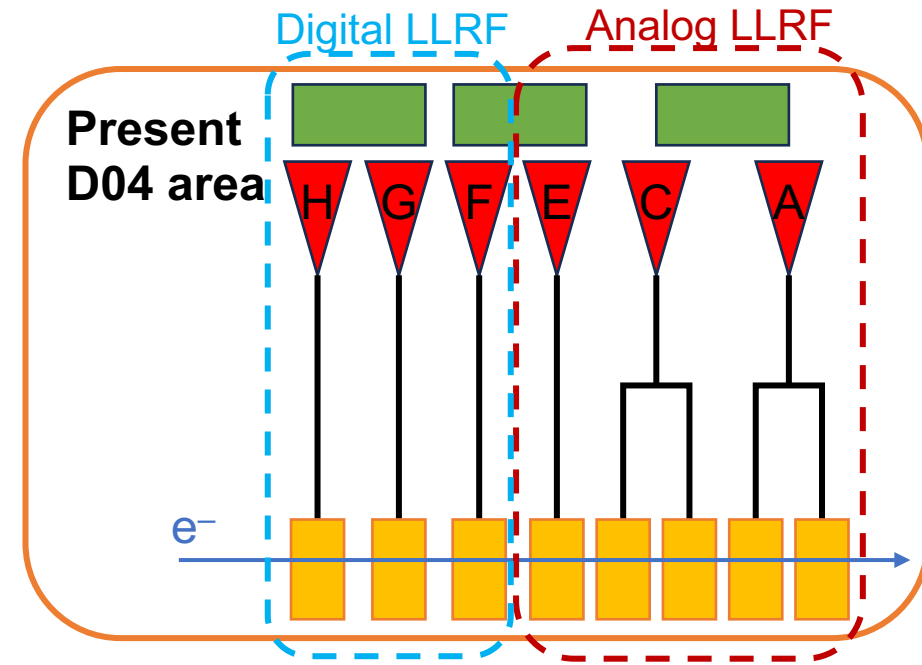

Present D04 control room

Upgrade on SCC HOM damper

Estimation of HOM power (M. Nishiwaki)

- At the number of bunches of 2346, the HER beam current will be limited up to ~2 A.
 - To achieve higher beam current, the reinforcement of SCC HOM damping system is required.

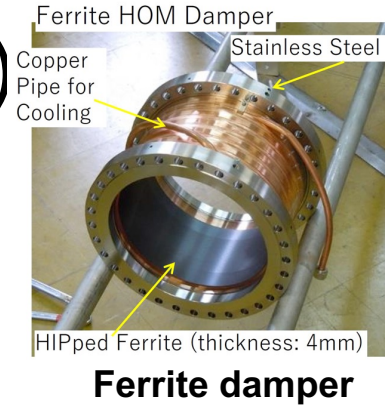

Ferrite damper

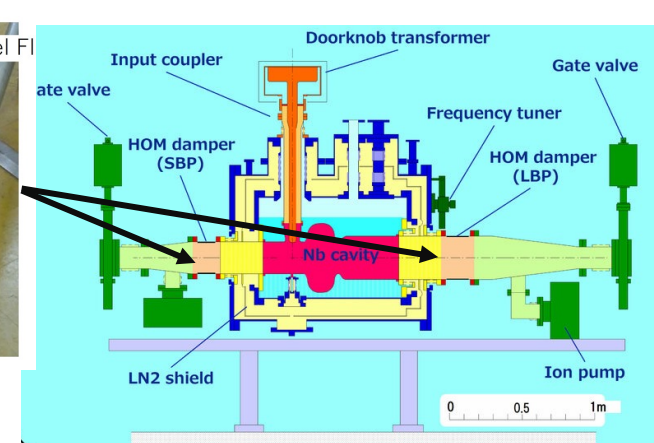

Limited by cooling capacity of chiller for each module : **2.07A**

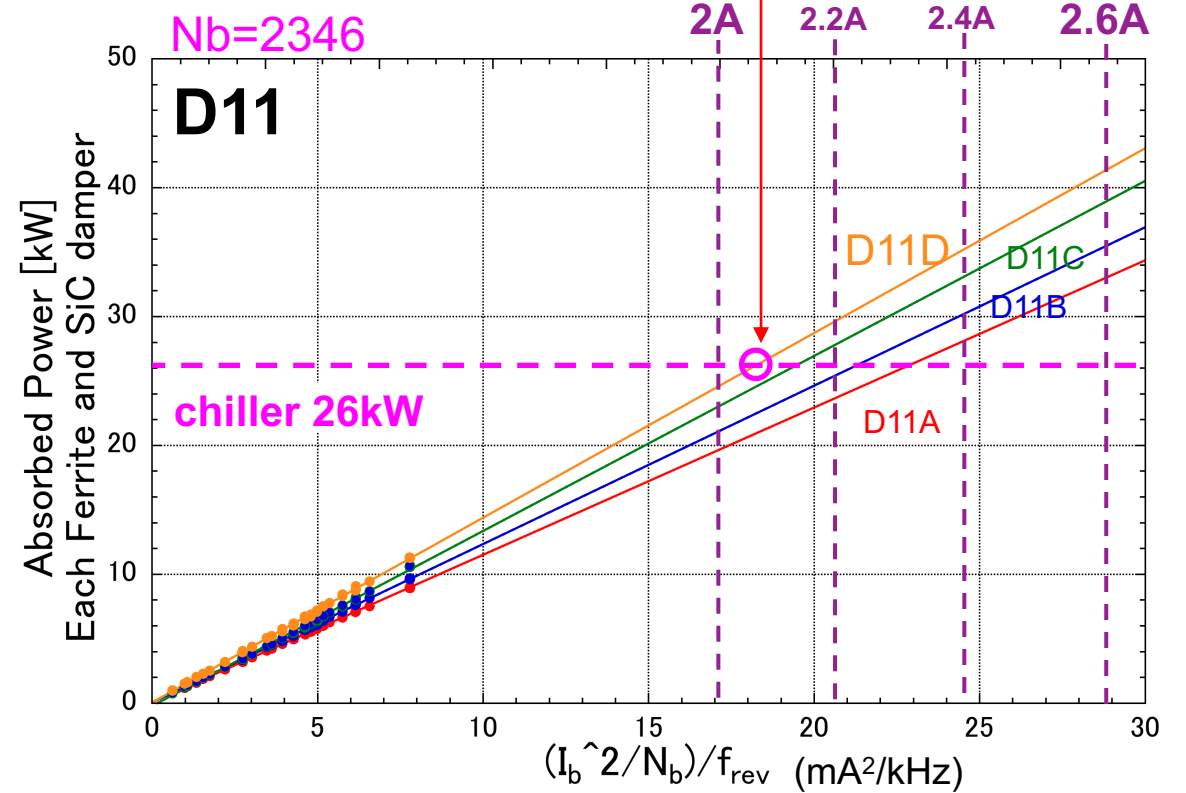
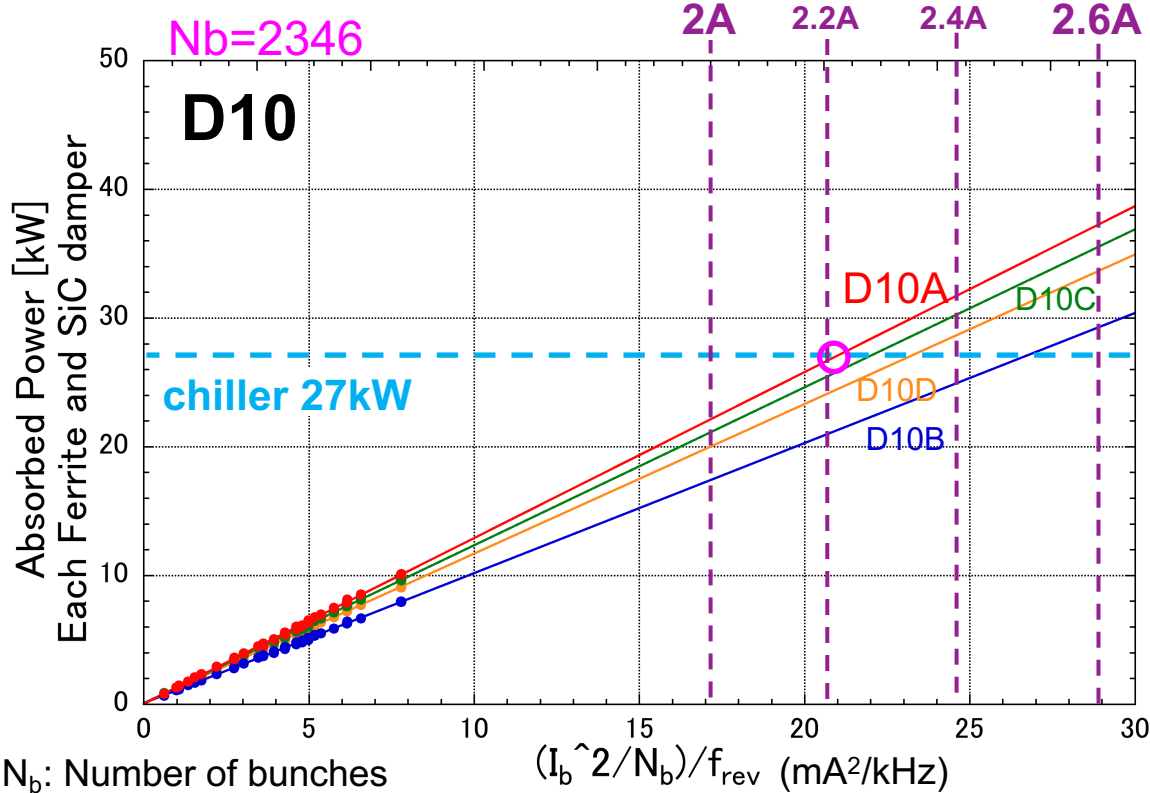

N_b : Number of bunches
 I_b : Average beam current
 f_{rev} : Revolution freq.

Present distribution of SCC HOM dampers

- SCC has two **ferrite dampers** in SBP and LBP.
- Ferrite dampers are cooled by a common chiller (cooling capacity ~25–27 kW).
- During the upgrade to SuperKEKB, two **SiC dampers** were newly installed between cavities.
 - Reduce propagating power to downstream cavities.
 - Mitigate power load of ferrite dampers.
- In the present layout, **D10A and D11D stations located downstream get largest power load.**
 - The main limit for HER beam current.
 - Upgrade required.
- Thanks to cooperation with Magnet group, the SiC dampers were able to be cooled by their cooling water since 2024c in D10 and 2025c in D11.
 - Further upgrade is not required for cooling of SiC dampers.
 - Upgrade cost was quite reduced.

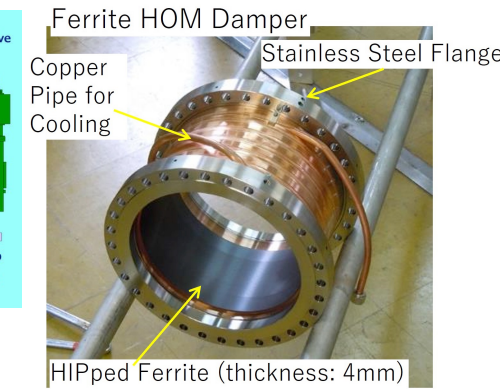
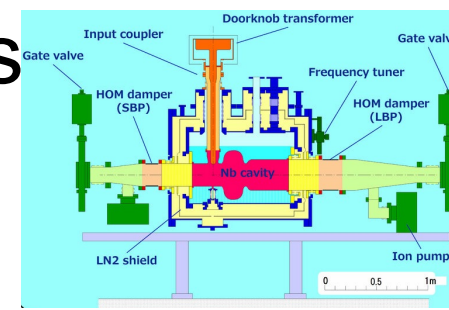

Ferrite damper

M. Nishiwaki, et al., SRF2023, pp. 38-42.

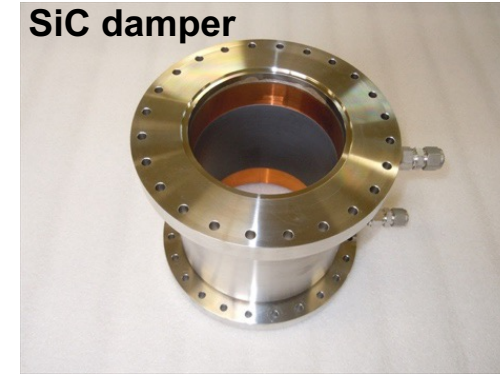

SiC damper

M. Nishiwaki, et al., PASJ2018, pp. 428-432.

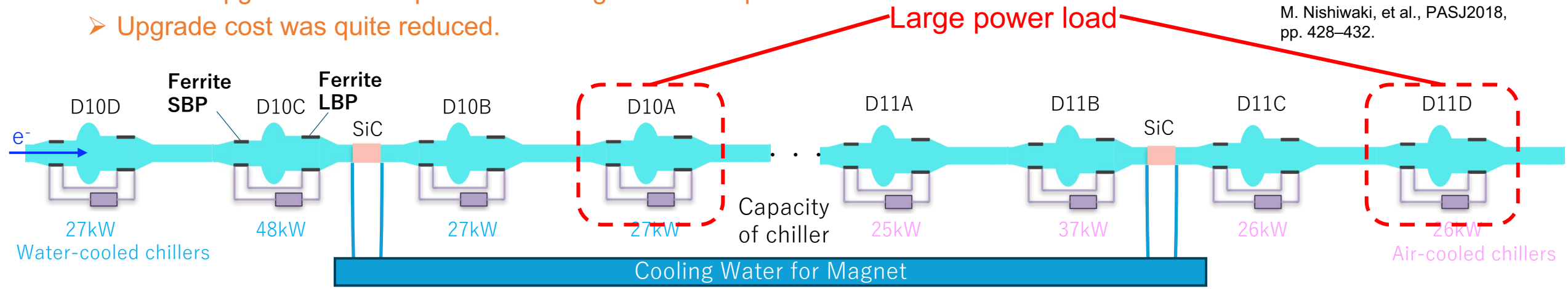

Distribution of HOM dampers and cooling channels

Plan to upgrade SCC HOM damping

- To mitigate power load of ferrite dampers, **SiC dampers must be installed between all cavities.**
 - Six SiC dampers (+ two spares) will be fabricated.
 - All the SiC dampers will be cooled by the magnet cooling water system.
- The chillers cooling the ferrite dampers should be **upgraded to larger capacity types.**
 - Eight 40-kW-class chillers (+ two spares) will be required.

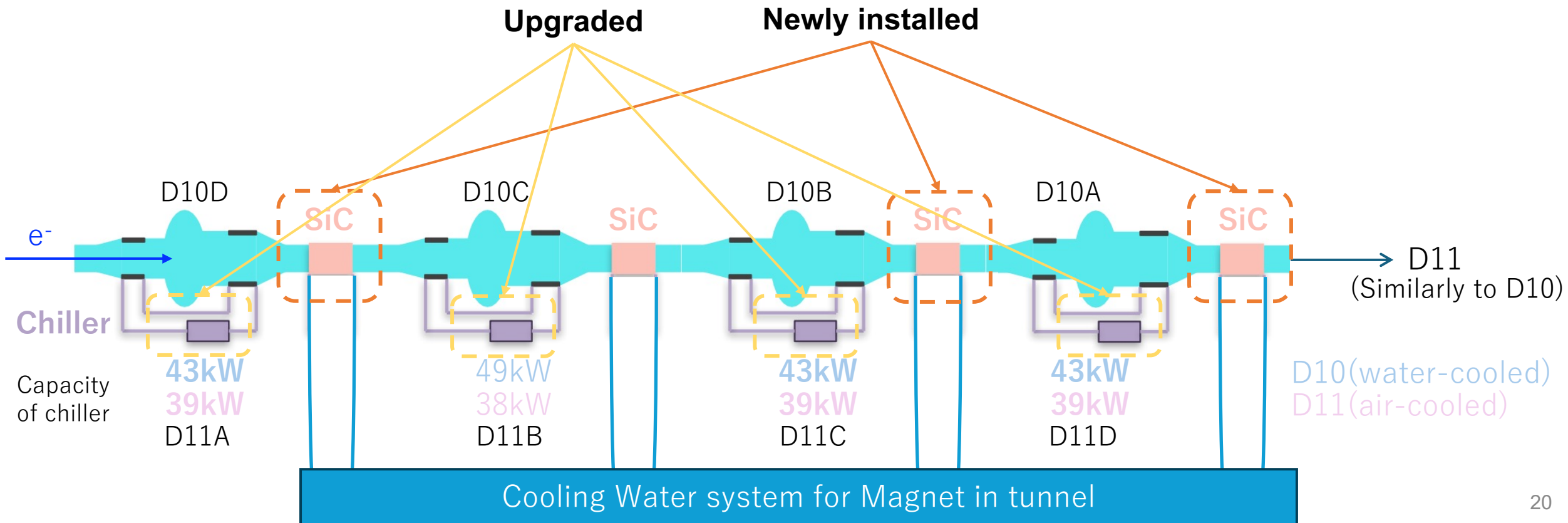

Upgrade schedule

- We need to start the preparation ~4 years before the LS2 starts (spec. drafting, public bidding, ...).

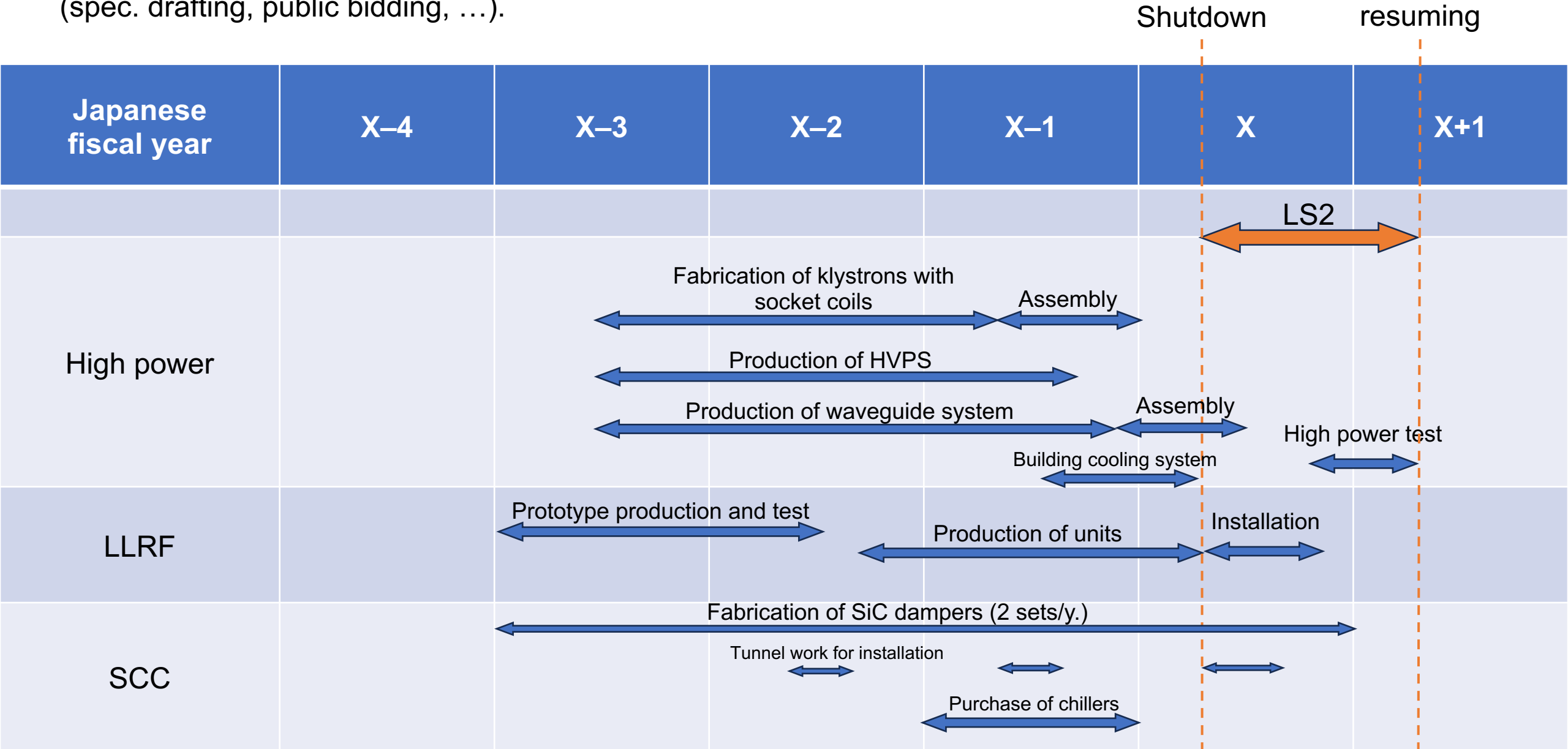

Summary

- In the present RF system, the HER beam current is limited up to ~2 A.
- The upgrade of RF system:
 - ✓ **High-power system in HER**
 - Increase two klystrons + one HV power supply in D04
 - Installation of digital LLRFs
 - ✓ **SCC HOM-damping system**
 - Increase SiC dampers
 - Reinforce the cooling system

Back up

RF System Arrangement

$f_{RF} = 508.9\text{MHz}$

Present State

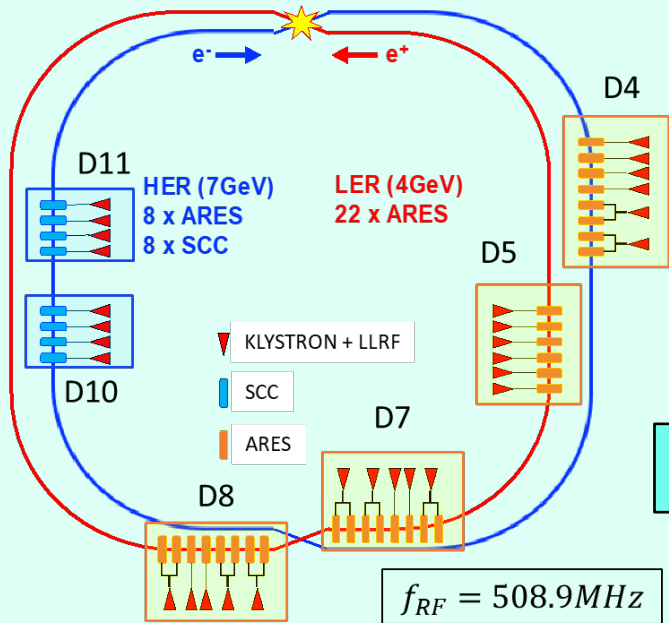

One-to-one configuration is required for most of ARES Station

For HER, all ARES stations should be 1:1 configuration for the design current.

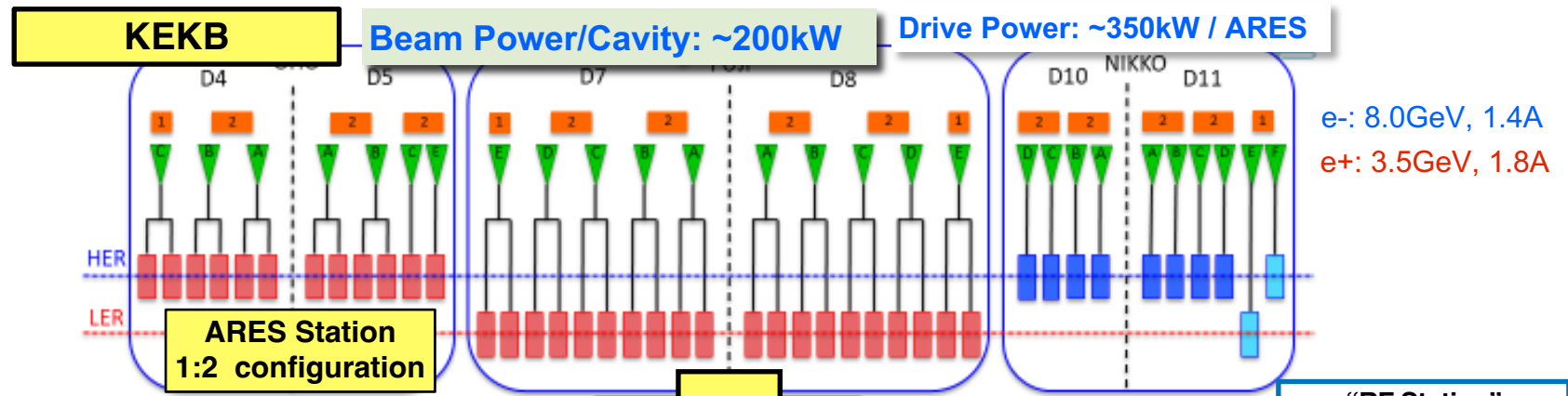

SuperKEKB (Present)

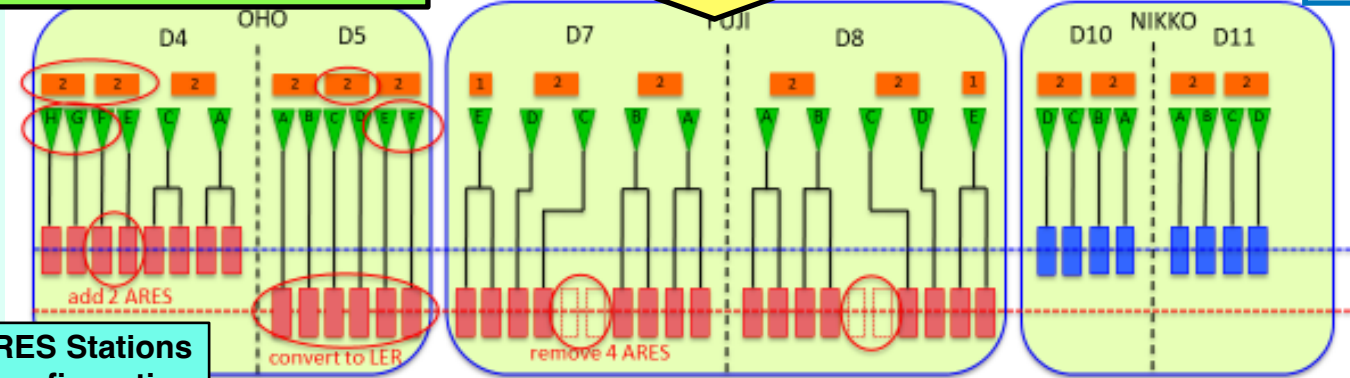

Some ARES Stations still 1:2 configuration

“RF Station” = an RF Unit driven by one klystron

- = HVPS
- ▼ = KLY+LLRF
- = SCC
- = ARES

SuperKEKB (Ultimate Case for the Design Current)

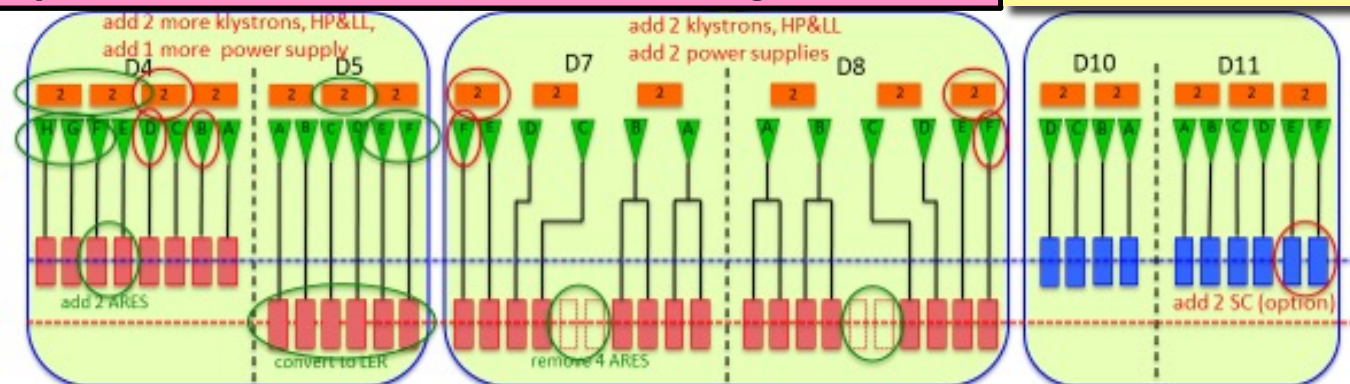

Beam Power/Cavity: ~600kW

e-: 7GeV, 2.6A
e+: 4GeV, 3.6A

Drive Power: ~750kW / ARES

Operation Status of LLRF Control System

(Since 2018, No significant changes in the system configuration)

MTCA-based Digital LLRF Systems, which was developed for SuperKEKB, are applied to **10 RF-stations** for ARES & DR.

In the other stations, **NIMBIN-Based Old Analog LLRF Systems**, which had been used in KEKB era, are still used.

CAMAC System is also still used for remote control of the old systems.

- All LLRF systems, including the reference signal distribution and instability-dampers are working well without fatal problems.
- Beam instabilities attributed to accelerating mode are successfully suppressed by the CBI damper and the Zero-mode damper. (CBI : Coupled Bunch Instability such as $\mu=-1$ mode)
- Recent concerns are increase of failures of NIM-bins and the modules due to aging of the old systems including CAMAC. (The most devices are discontinued, and the spares are not enough.)
Even the digital systems with FPGAs&linux, which was developed in 2012, are becoming out-of-dateness.

(Upgrade of the old ones to new digital system is required, but it is difficult because of insufficient budget and time.)

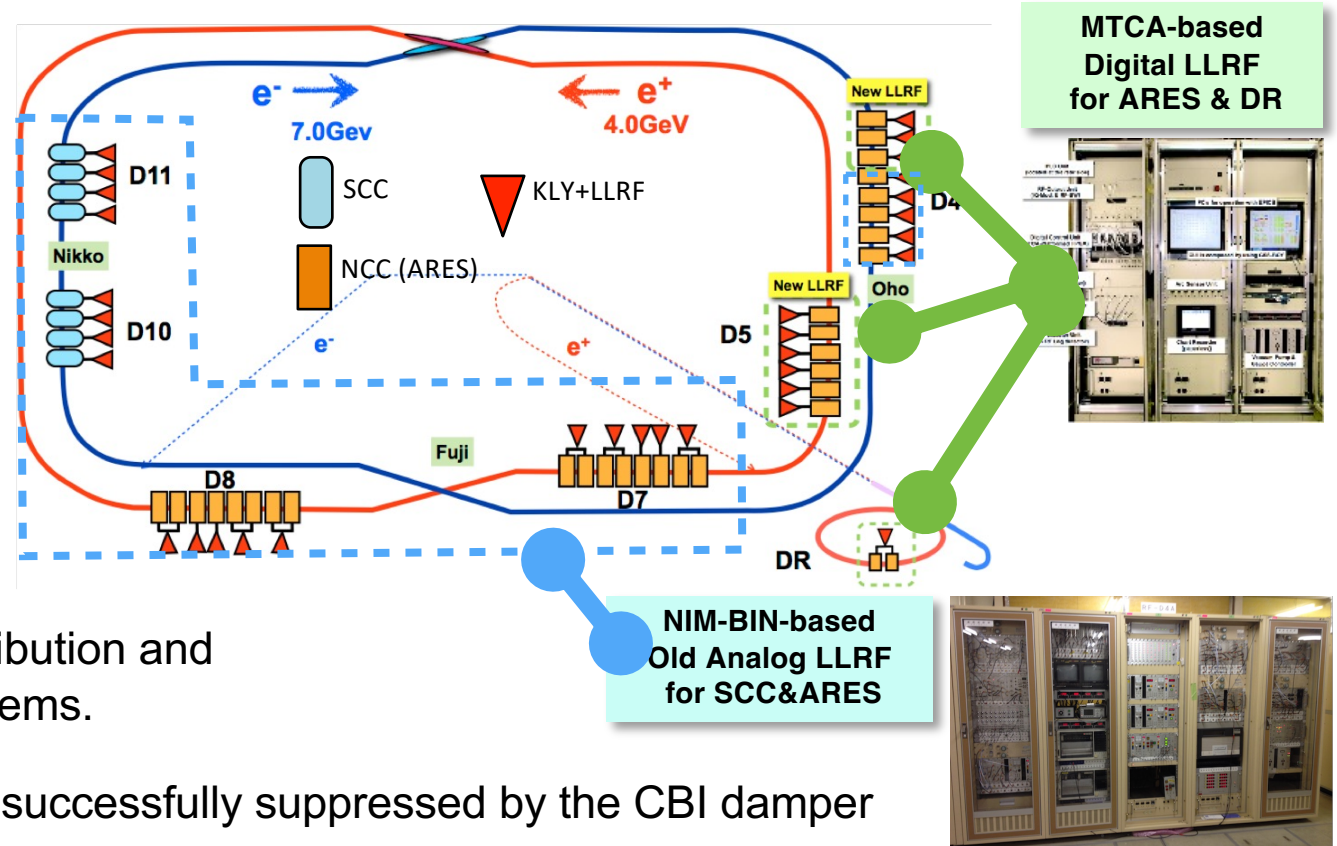

Digital LLRF Control System

Digital LLRF control system has been newly developed for high accuracy and flexibility in 2012

New LLRF System for one klystron

16-bit ADC x 4ch,
16-bit DAC x 2ch

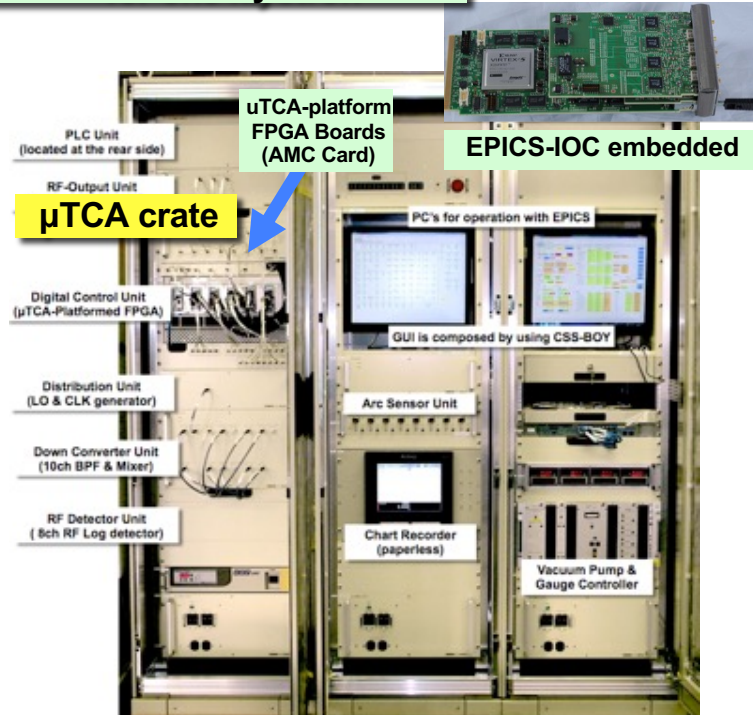

LLRF System

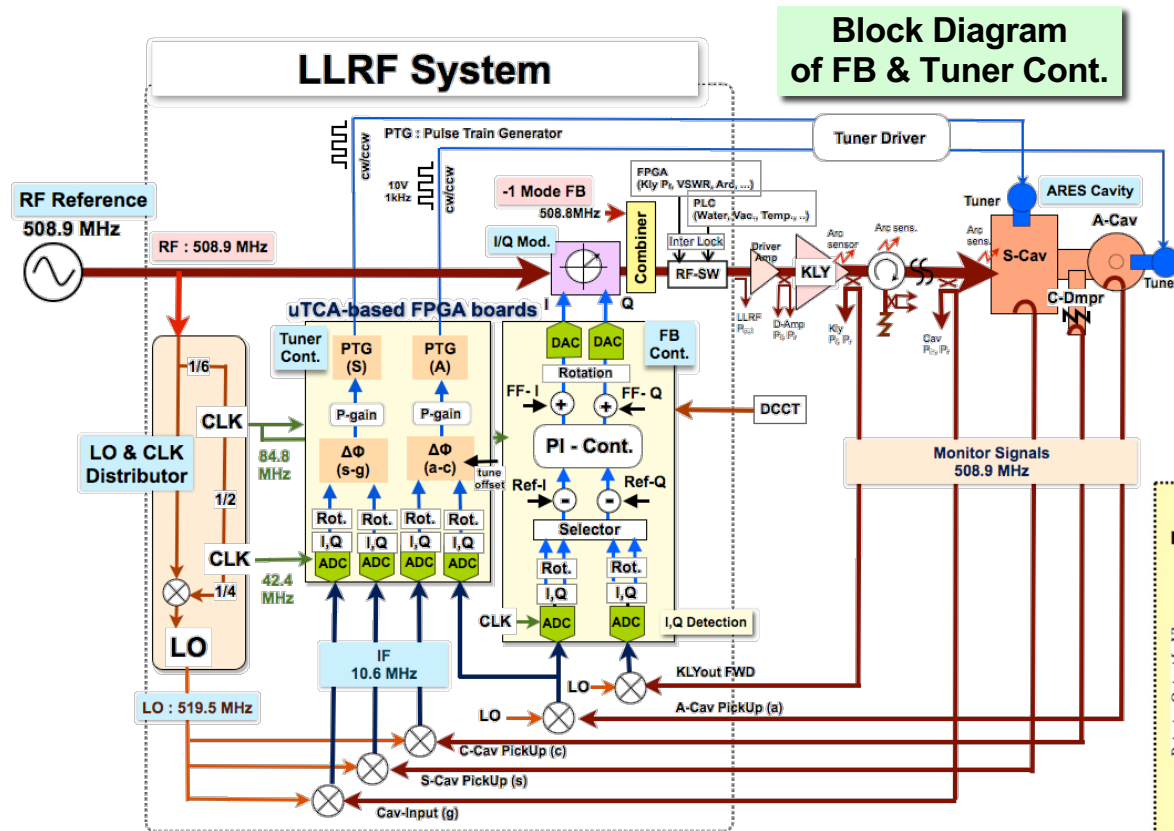

Block Diagram of FB & Tuner Cont.

Regulation Performance

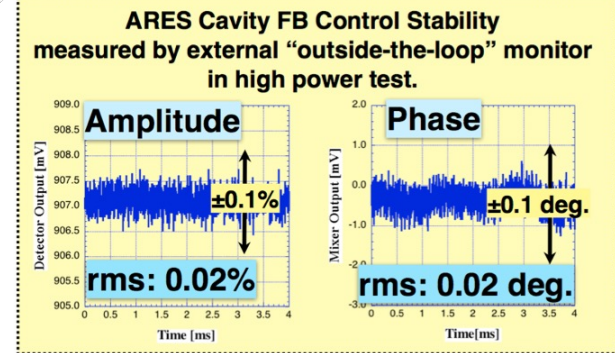

- Consisting of μTCA-platformed FPGA boards (AMC), & PLC.
- EPICS-IOC with Linux-OS is embedded in each of them.
- Common hardware for both of ARES & Superconducting Cavity.
- Klystrons (LLRF) : Cavity unit = 1 : 1 (SuperKEKB)
Completely remote controllable

- It is dominated by μTCA-platformed FPGA boards for higher accuracy and flexibility.
- In this system, I/Q components are handled by FPGA for vector control instead of amplitude and phase.
- The good performance was demonstrated in the high power test with ARES cavity., The regulation stability was 0.02% in amplitude and 0.02 deg. in phase.

Old Analog LLRF Control System

Most stations are still operated by old analog LLRF systems, which had been used in KEKB operation.

Analog LLRF
used since KEKB operation

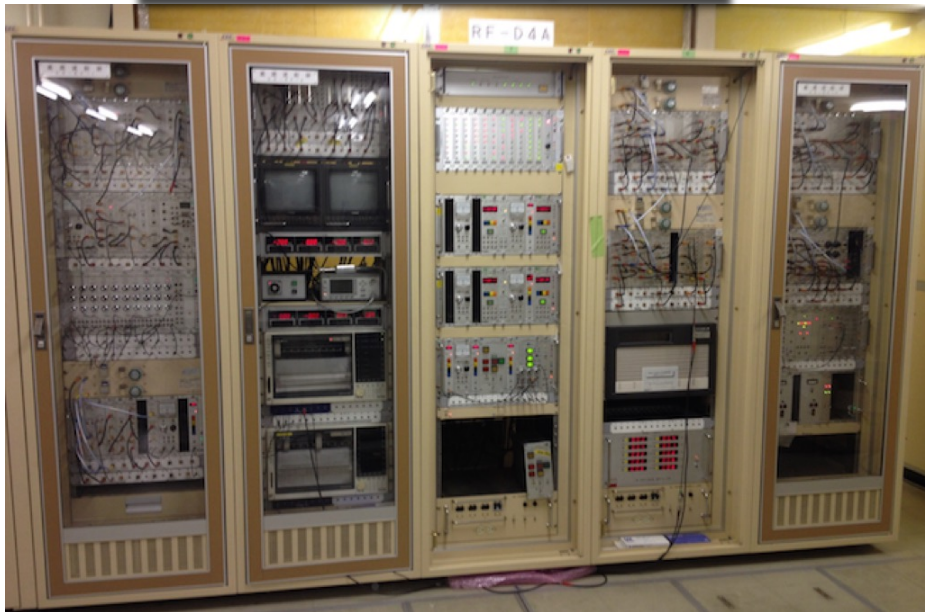

Block Diagram of Analog LLRF

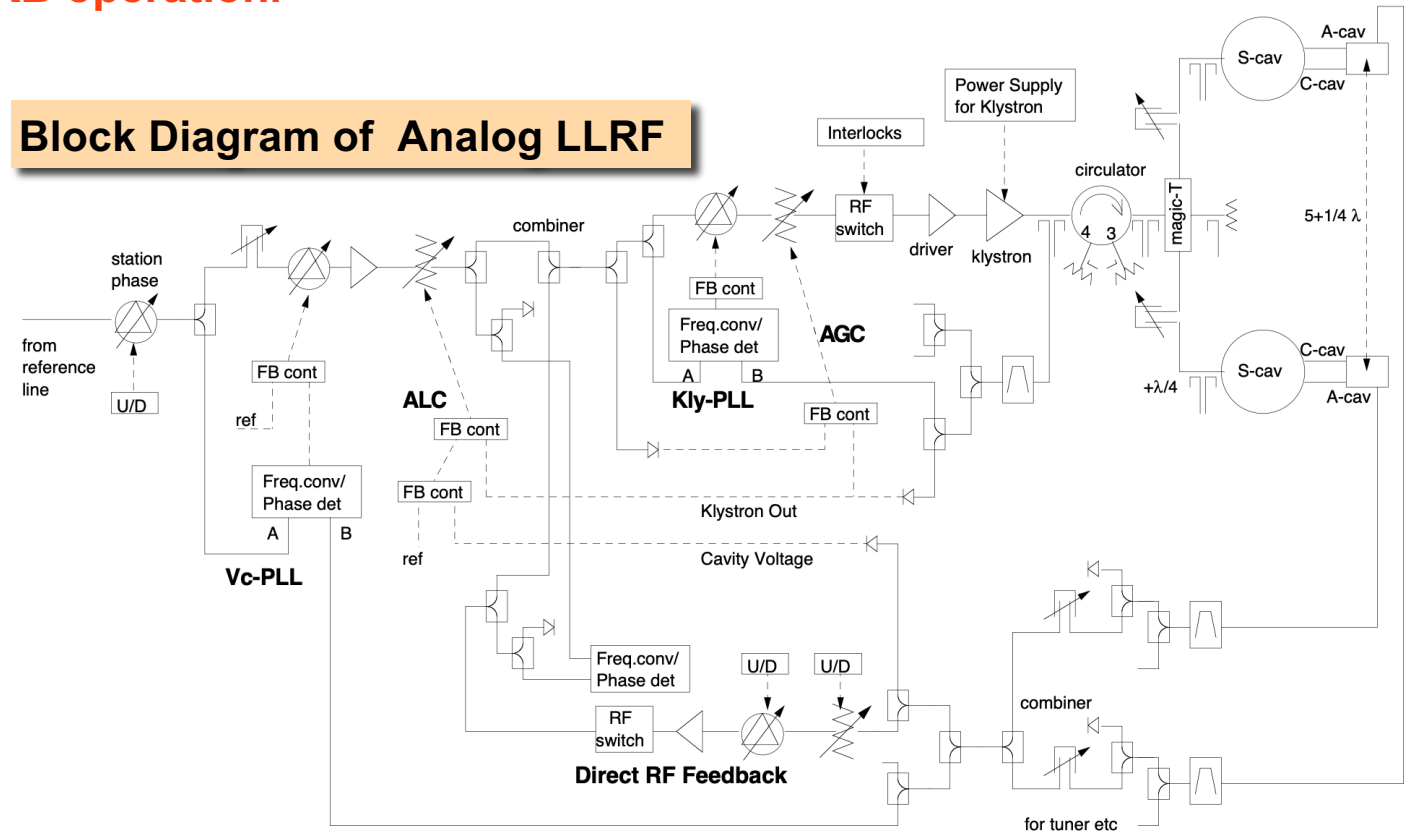

- These systems are composed of combination of NIM standard analogue modules.
- They are controlled remotely via CAMAC system.
- All systems are barely working without serious troubles.
However, some NIM modules failed during operation. They were replaced with spares.
- The most devices are discontinued, and the spares are not enough.

Estimation of Growth Rates of Coupled Bunch Instability (CBI)

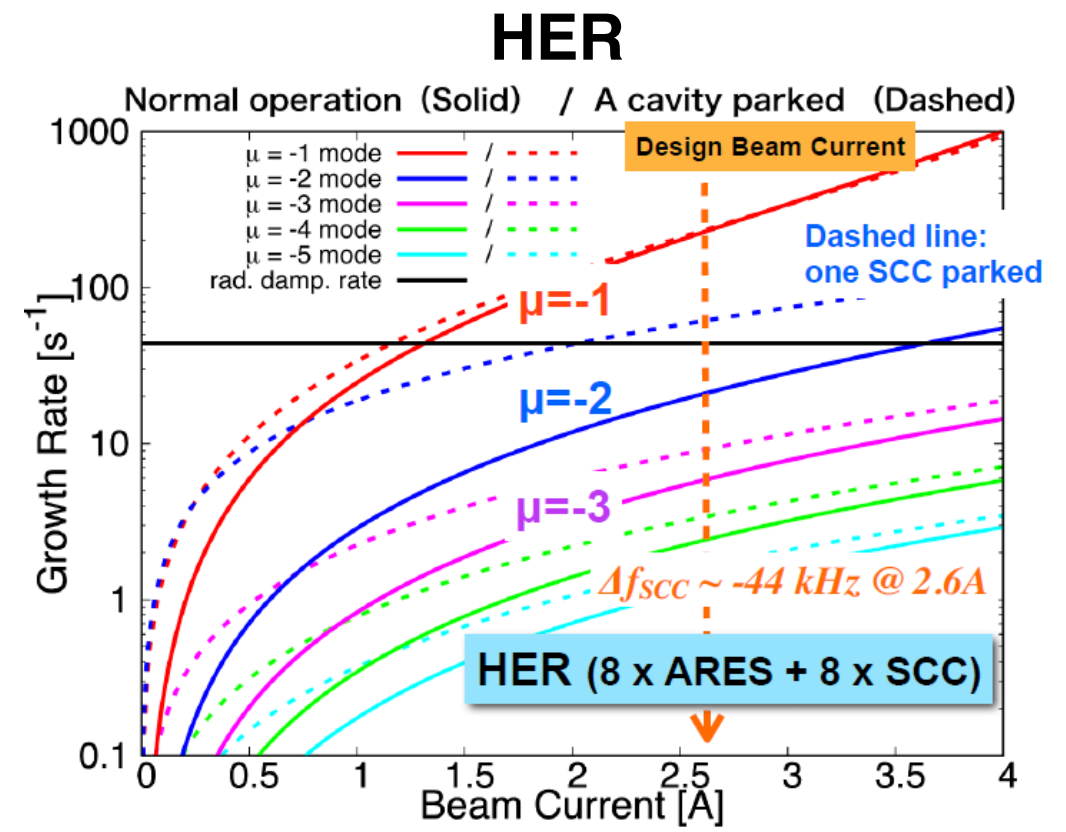
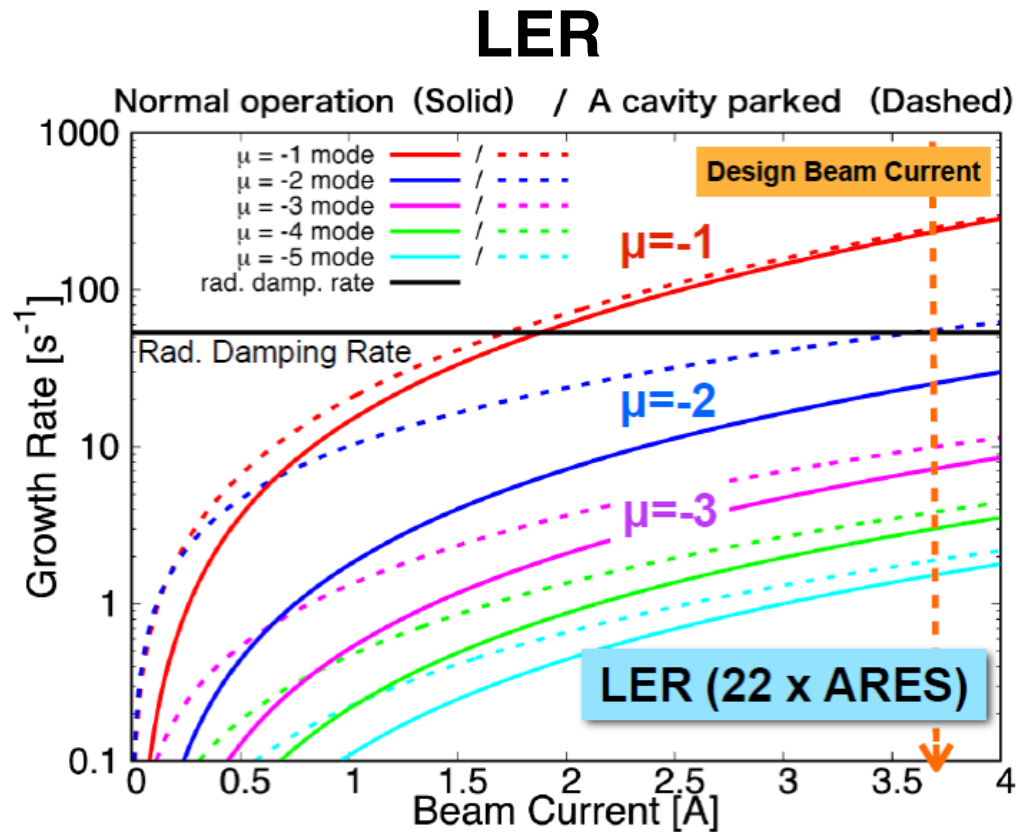

Threshold currents for $\mu=-1$ mode are quite below the design current.

When there are parked cavities, $\mu=-2$ mode also has no margin.

New CBI damper system has been developed and installed.

CBI Damper System

K. Hirosawa et al., Nucl. Instrum. Methods. Phys. Res. A 951, 163044, 2019.

The damper system is installed to ARES station with digital LLRF system.

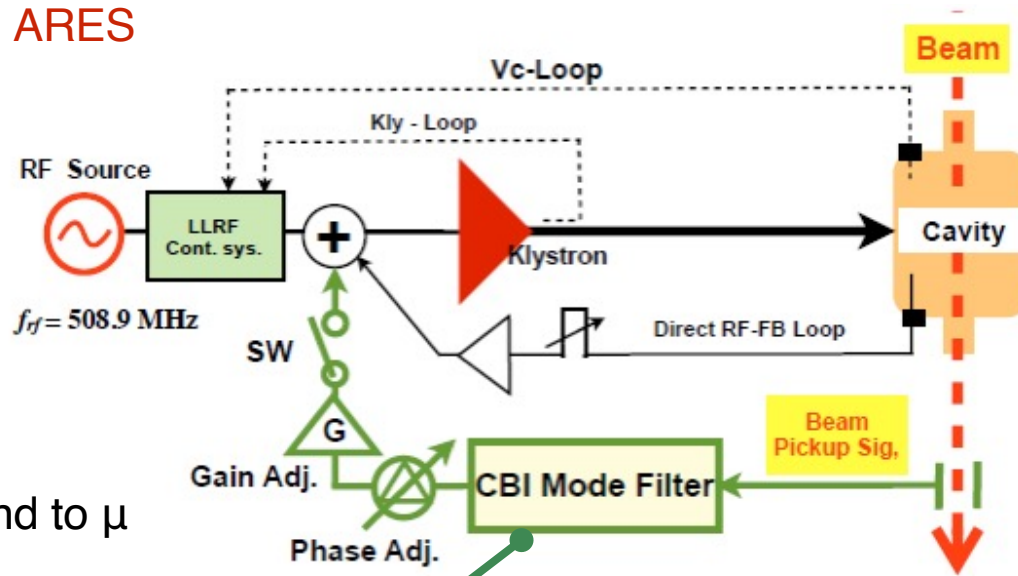

The damper system can correspond to $\mu = -1, -2$ and -3 modes in parallel.

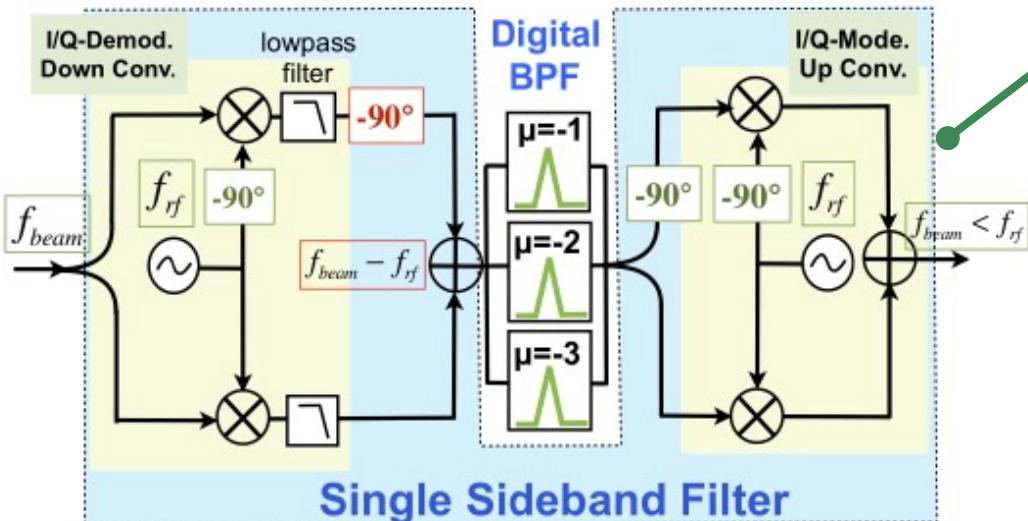

FB loop test result of the CBI mode filter for a simulant cavity

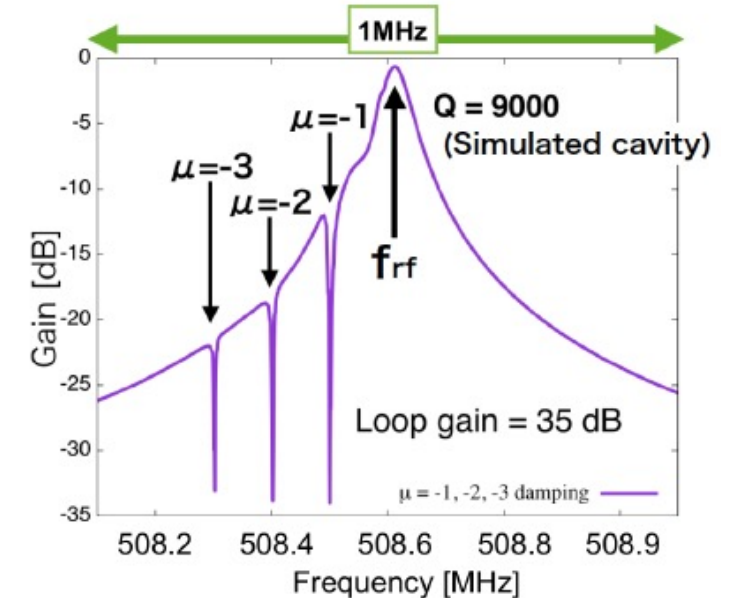

Impedance at the frequencies corresponding to $\mu = -1, -2$ and -3 modes are suppressed by the damper.

Zero-mode Instability related to Robinson Stability

K.Akai, PRAB 25, 102002 (2022).

- In high current operation, synchrotron frequency reduction is expected due to coherent oscillation (zero-mode).
- To mitigate the beam-loading effect, Direct RF feedback (DRFB) and Zero-mode damper (ZMD) are working.

Calculated coherent oscillation frequencies with **simplified one SCC** for various Q_L (without FB for instabilities)

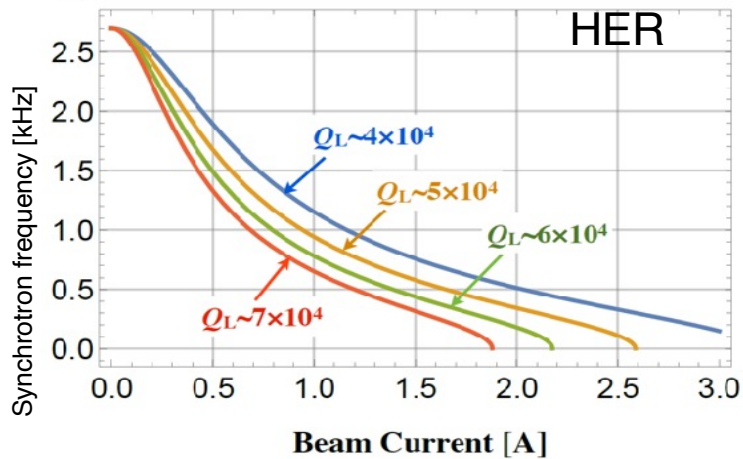

Synchrotron frequency reduction depends on Q_L . But, changing Q_L of SCC should be avoided due to the need for vacuum work and the risk of surface contamination.

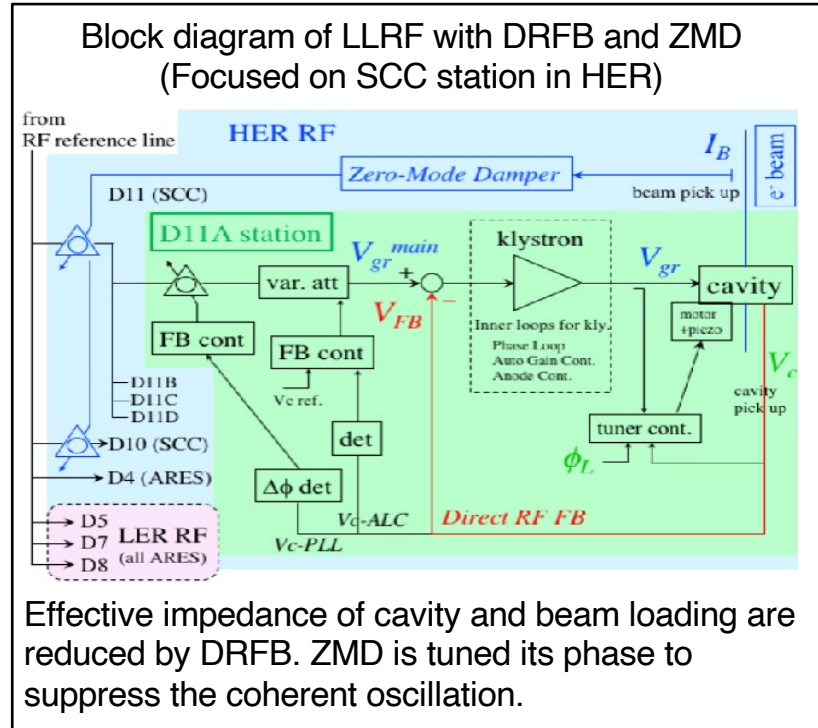

Calculated and measured coherent oscillation frequencies in **actual HER (ARES + SCC)** with DRFB **Off, -6.0dB and -4.5dB**

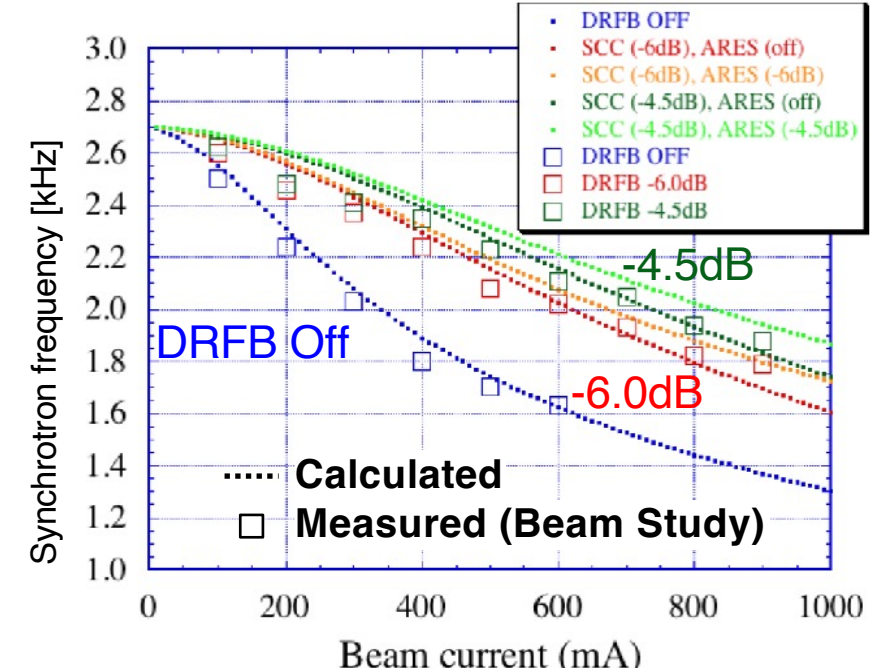

- The higher beam current can be stored stably by DRFB and ZMD in beam study.
- There is no discrepancy between the quantitative analysis and the beam study results.
- Coherent oscillation instability is not a problem with the DRFB and ZMD so far.

RF Reference Distribution System

- RF reference signal is **optically distributed** into 8 sections by means of “Star” topology configuration from the central control room (CCR).
- For the thermal phase drift compensation, **variable optical delay line (VODL)** is **controlled** digitally by using μ TCA board at CCR for all transfer lines. The VODL is a mechanical type. The stepping motor is controlled by the μ TCA boards with pulse train outputs like cavity-tuner control.
- For the phase monitor, **direct sampling method** is applied by using 14-bit ADC boards. It is under sampling at 212 MHz for 509-MHz RF signal.

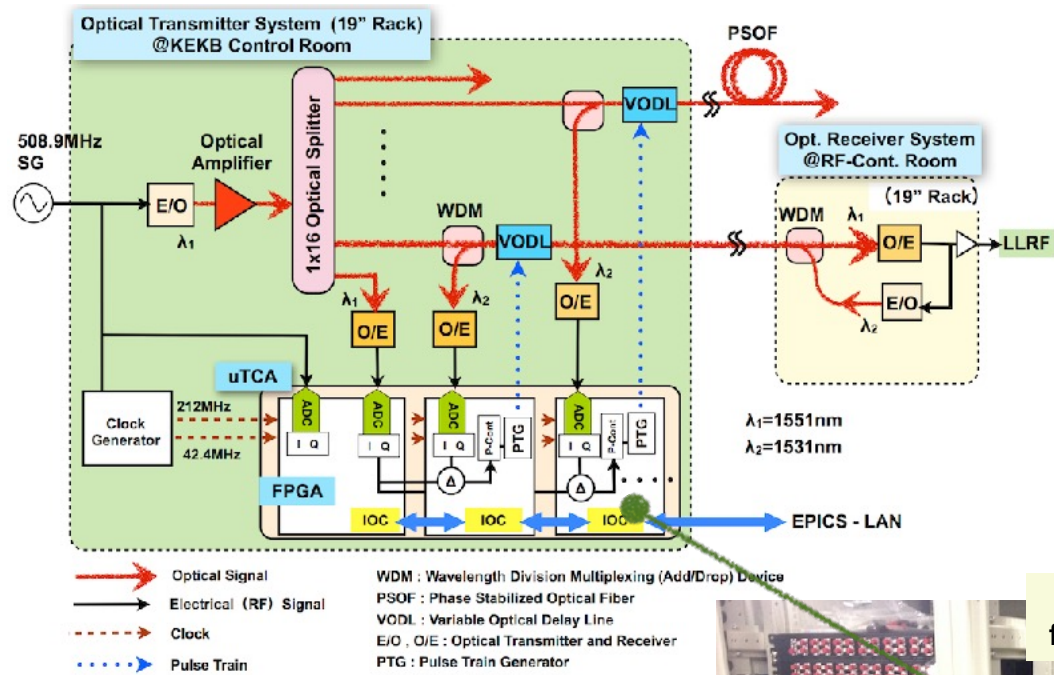
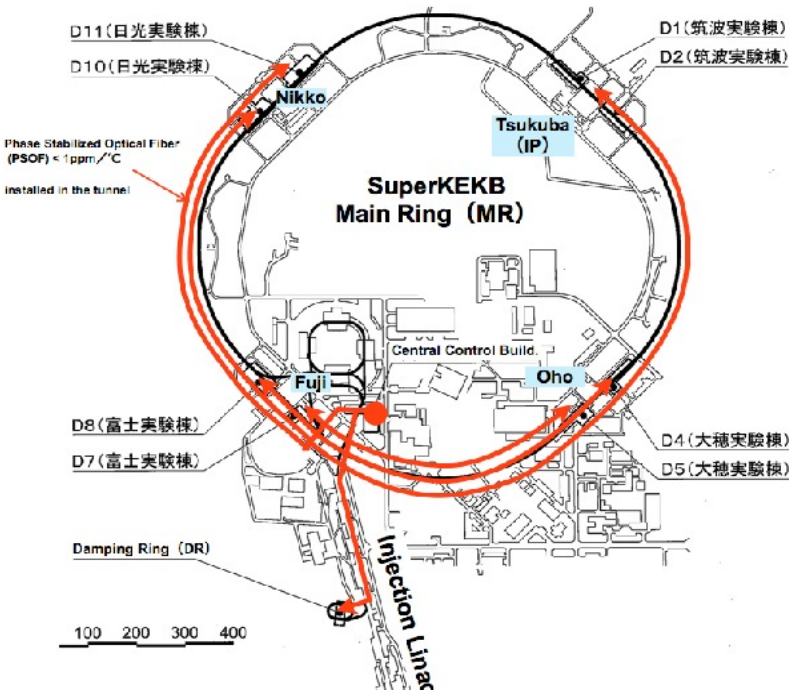

Low SSB Phase Noise

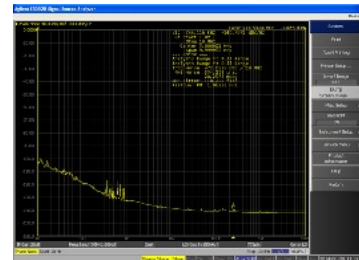

Short term stability (time jitter) : $< 100 \text{ fs (rms)}$
 Long term stability (pk-pk) : $\pm 0.1^\circ @ 508.9\text{MHz} = \pm 0.55 \text{ ps}$
 (attributed to property of the optical delay control)

It is working successfully without troubles, and also completely reproduces the RF phases and the collision point for restart after long shutdown.

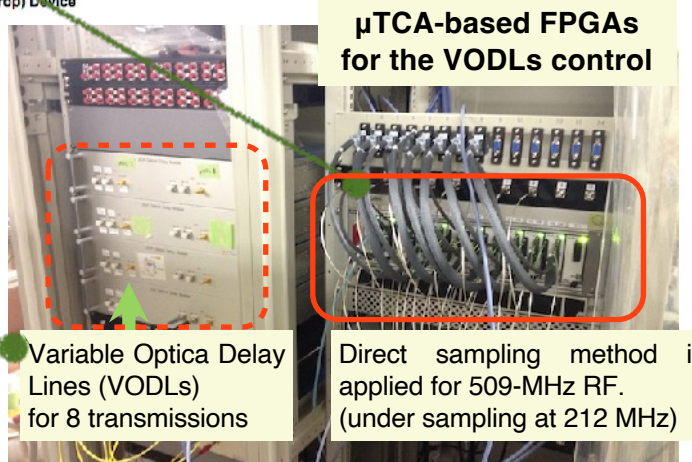
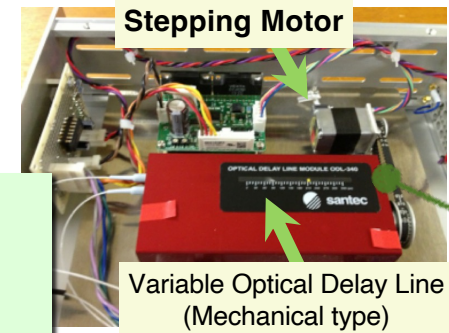

Variable Optical Delay Lines (VODLs) for 8 transmissions

Direct sampling method is applied for 509-MHz RF. (under sampling at 212 MHz)

Statistics on klystrons (M. Yoshida)

Total klystron operation time after 2024ab run

MR + DR + AR + spares: 41 klystrons

year: 1986-2024

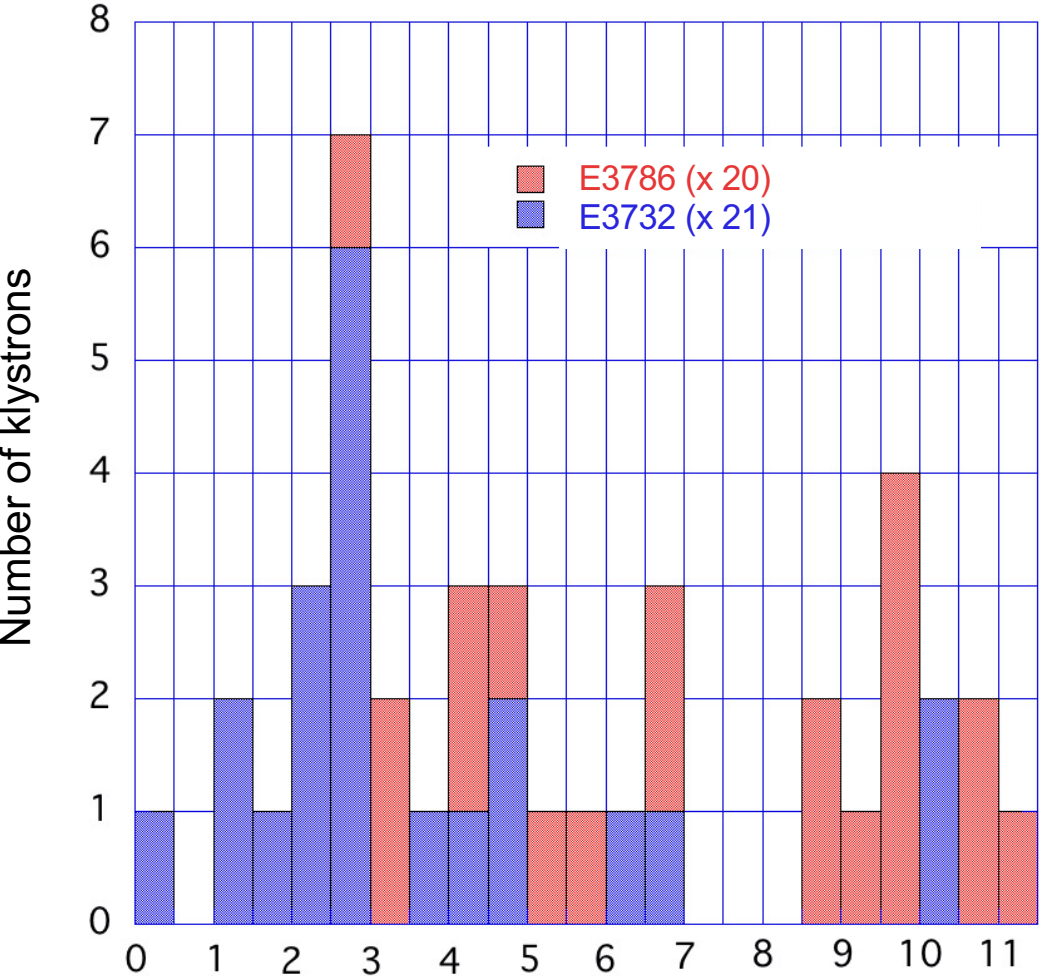

Total operation time (LV or HV) [$\times 10,000$ h]

Lifetime of klystrons

year: 1986-2024

Total # of klystrons: 38 (E3786: 30, E3732: 8)

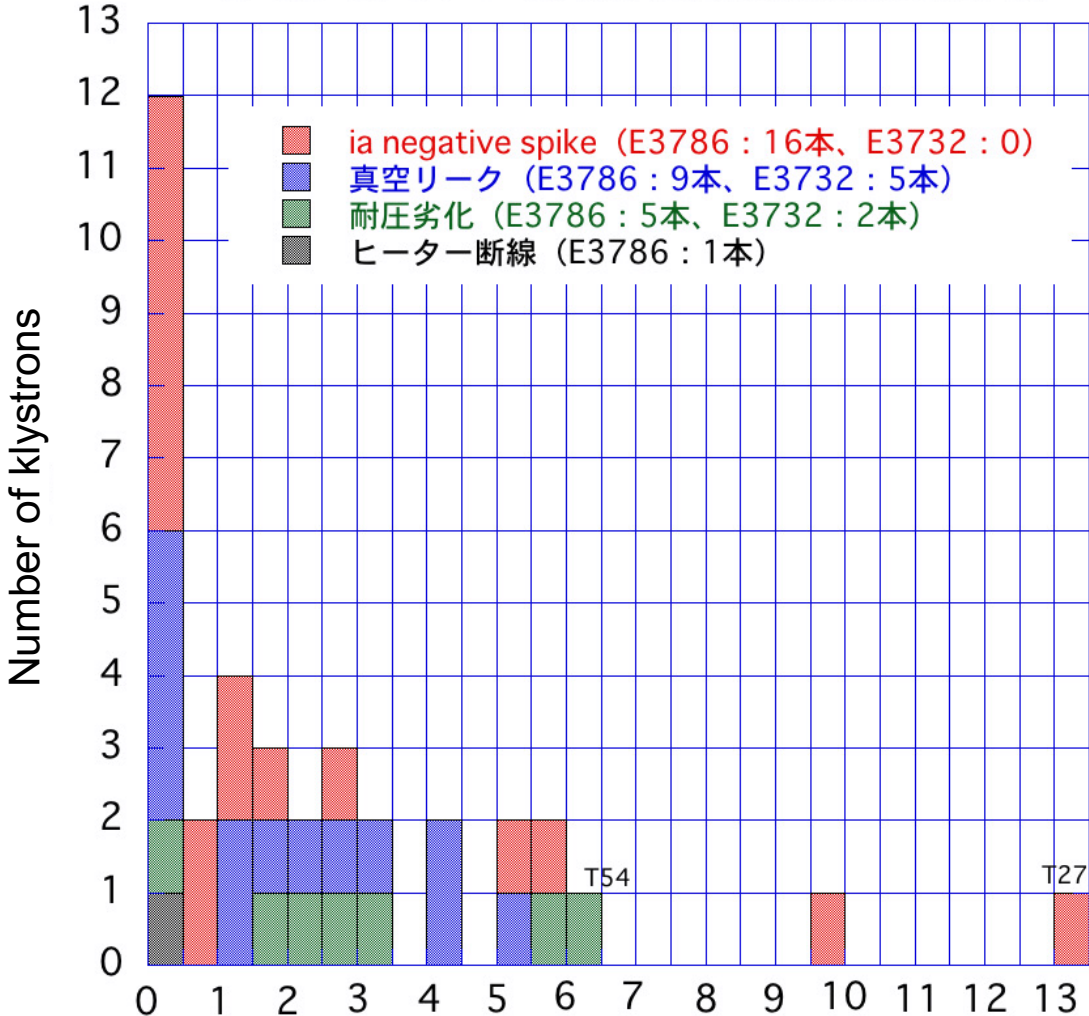

Total operation time (LV) [$\times 10,000$ h]