

CONSTRUCTION OF THE J-PARC L3BT CONTROL SYSTEM

G. Shen^{A)} #, K. Watanabe^{A)}, Y. Kato^{A)}, H. Sakaki^{A)}, H. Sako^{A)}, Y. Ito^{A)}, H. Yoshikawa^{A)},
K. Hanawa^{B)}, S. Mizuno^{C)}

^{A)} Japan Atomic Energy Agency (JAEA), Ibaraki, 319-1195, Japan

^{B)} Toshiba Corporation, Tokyo, 183-8511, Japan

^{C)} Shinryo High Technologies Ltd., Hyogo, 652-0865, Japan

Abstract

The control system of J-PARC project is under construction. After almost finishing the hardware installation of the L3BT section, an online device commissioning was performed for magnet power supply, stepping motor and vacuum system.

Many components for device control have already been developed separately, but not integrated together yet. It is the first experience to combine all the components, including core software for a front-end IO controller, an EPICS run-time database, and a remote graphic user interface.

This paper describes the detail of the recent construction status of the L3BT control system, including component development, system integration, and device commissioning.

INTRODUCTION

J-PARC (Japan Proton Accelerator Research Complex) ^[1, 2] is a high-intensity proton accelerator, which includes a 181-MeV LINAC, a 3-GeV RCS (Rapid Cycling Synchrotron) ring, and a 50-GeV MR (Main Ring) ring.

L3BT ^[3] is a beam transport line from the LINAC to the RCS ring. It consists of a straight section, an achromatic arc section, a scraper section, an injection section and 5 beam dumps as Fig. 1 illustration.

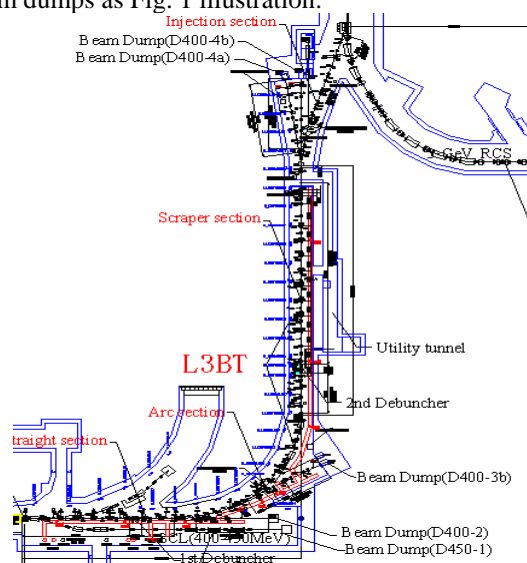

Figure 1: Layout of the L3BT.

The control system of J-PARC project is constructed using an EPICS (Experimental Physics and Industrial

Control System) ^[4] software tool-kit, which has been utilized in many accelerator control systems. The L3BT control system adopts a standard EPICS architecture, including a device interface layer, an equipment control layer, and a presentation layer.

The device interface layer consists of an interface to hardware subsystem. The magnet power supply and the stepping motor are controlled by VME-bus based IO modules. The vacuum system is controlled by network-based PLC (Programmable Logic Controller).

The equipment control layer, or an IOC (Input Output Controller) layer in EPICS term, equips with a VME-bus based SBC (Single Board Computer). All control functionalities are realized inside an IOC. It supports many modern operating systems, including Linux, vxWorks, and MS Windows. The L3BT control system adopts vxWorks as a main operating system for IOC.

All application programs for commissioning/operation run on the presentation layer, which is also known as an OPI (Operator Interface) layer in EPICS term. A set of desktop PC are used as the operation platform, which run a Linux operating system.

EQUIPMENT CONTROL

EPICS device driver and device support

A series VME-bus based IO module from the ADVANET Company, are used for controlling the magnet power supply and the stepping motor. All module types are listed in Table 1, which are used in the L3BT control system. An EPICS device driver and device support for those modules was developed by the J-PARC control group. All supported EPICS records are listed in the Table 1 also.

Table 1: VME-bus based IO modules

Type	Board Name	Supported Records
Digital Input	ADVME1211	bi, mbbi, mbbiDirect, longin, ai
Digital Output	ADVME1314	bo, mbbo, mbboDirect, longout, ao
Analog Input	ADVME2607	ai
Analog Output	ADVME2706	ao
Pulse Controller	ADVME2004	jsm, steppermotor, bi, mbbi, mbbiDirect, mbbiDirect, bo, mbbo, mbboDirect, longout,

#shen.guobao@jaea.go.jp

An analog input or output of steering magnet is controlled using a normal analog input or output module. But a bending or quadrupole magnet power supply is controlled using digital input and output board. A special EPICS ai or ao record, which is for digital input or output board, was developed to simulate an analog input or output. That special ai or ao record converts value to or from an analog value respectively.

For a stepping motor control, an EPICS record, jsm, was developed by extending a standard EPICS stepping motor record.

The vacuum system is controlled using a PLC, FA-M3 from the YOKOGAWA Company. A device driver and device support was developed for the PLC. The EPICS records that it supports include bi, bo, longin, longout, mbbi, mbbo, mbbiDirect, and mbboDirect.

IOC run-time database

IOC behaviour is determined by a run-time database that is a collection of standard function blocks, or records in EPICS. A machine signal can be described using an EPICS record, which consists of a group of EPICS fields.

All machine information and EPICS parameters are managed using a RDB (Relational Database) server [5]. The PostgreSQL is adopted as a RDBMS. The machine signal information collected by device group or manufacture is saved into the RDB server [6]. To generate an EPICS run-time database for each IOC from the RDB server automatically, a dedicated schema is developed. Fig. 2 demonstrates using a RDB manager client to manage the machine signal.

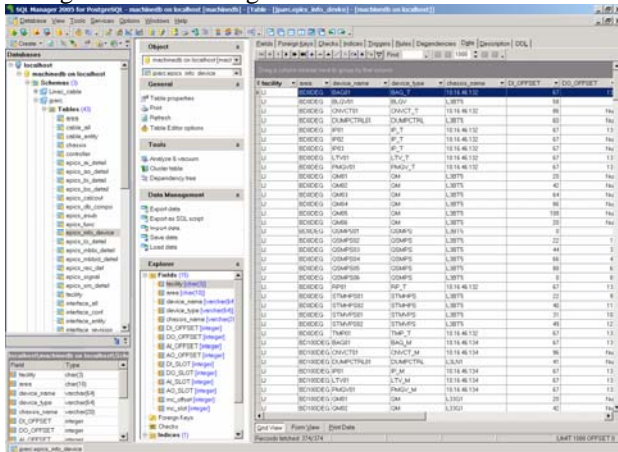

Figure 2: Database Management for EPICS.

Up to now, the EPICS run-time database for 3 difference interfaces, including VME and PLC, can be generated from the RDB server automatically [6]. All run-time databases for L3BT magnet power supply and vacuum have been generated automatically.

A Java based application is developed to generate a run-time database from RDB according the J-PARC EPICS naming rules as Fig. 3 illustration. All necessary information is read from the RDB server for a specified IOC, and written into local files according the conventional format of EPICS run-time database.

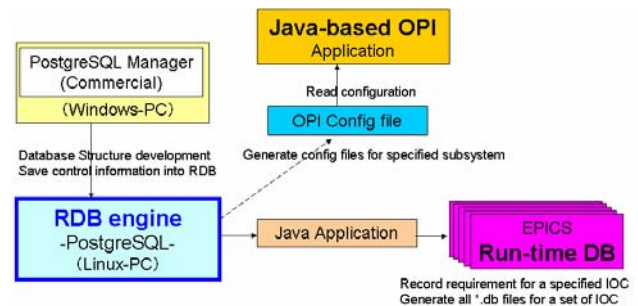

Figure 3: EPICS run-time database generation.

Since all EPICS parameters and machine signals are saved in the RDB server, it is also possible to generate a configuration file for a Java-based high level application.

OPI APPLICATION

An OPI application runs on the presentation layer, which consists of console and server typically.

The OPI for magnet power supply consists of top-view and sub-view developed using the Java program language. The top-view consists of buttons for sub-view. One button is for one sub-view. Considering the convenience of field commissioning, the button is arranged according IOC location. All power supplies controlled by one IOC are listed following IOC name, and button of sub-view is arranged according the location of power supply. The detail information of each power supply is described in a sub-view, which controls one power supply. Fig. 4 illustrates the top-view and one sub-view.

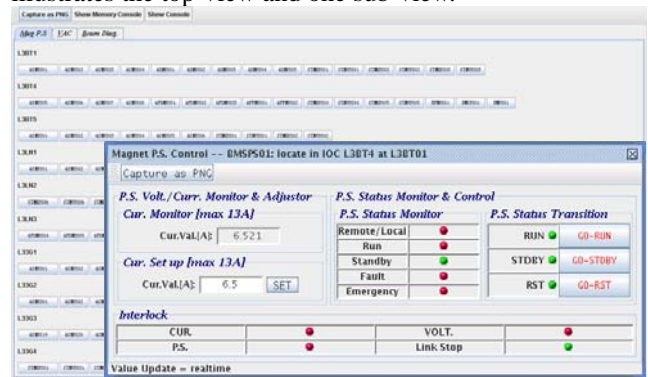

Figure 4: OPI for magnet power supply.

The OPI for stepping motor is developed using the Java program language also. Fig. 5 demonstrates an OPI example for the stepping motor control.



Figure 5: OPI for stepping motor.

The OPI for the vacuum is realized using an EPICS extensions tools, MEDM (Motif Editor and Display Manager). It adopts the same policy, and includes a top-view, a group sub-view and a device sub-view as Fig. 6 illustration.

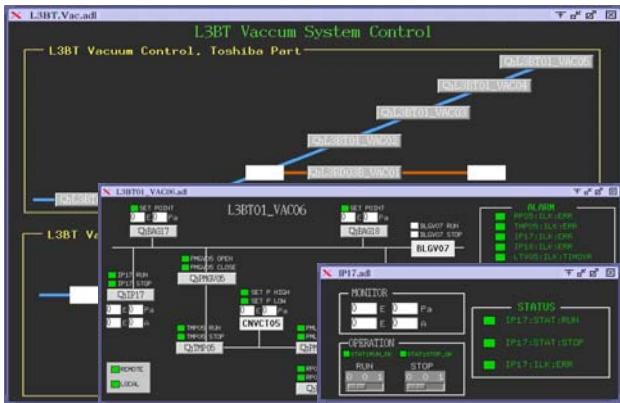

Figure 6: OPI for vacuum system.

The top-view is arranged according the location of vacuum station. One button corresponds to one vacuum station, which consists of many devices in one location. The group sub-view consists of buttons and some critical status monitor for vacuum device. The device sub-view describes the detail information for each vacuum device.

DEVICE COMMISSIONING

An online device commissioning has been performed for magnet power supply, stepping motor and vacuum system. The purpose is to check and verify the software and hardware functionality, remote controllability, and cable connection.

The system configuration is illustrated in Fig. 7.

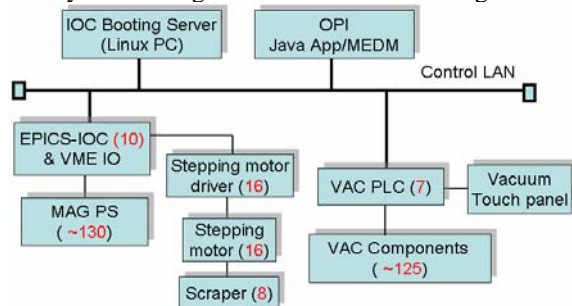

Figure 7: OPI for vacuum system.

In the device interface layer about 130 magnet power supplies are controlled by the VME-bus based IO modules from ADVANET Company. Eight Scrapers are controlled using 16 stepping motors, which are driven by 16 stepping motor drivers. About 125 vacuum devices are controlled by 7 YOKOGAWA FA-M3 PLCs.

The equipment layer consists of 10 IOCs, which adopts an Advme-7501 SBC from ADVANET Company, and runs vxWorks 5.5.1. The IOC software is compiled against EPICS Release 3.14.7.

There are about 2157 control points for magnet power supply, 64 control points for stepping motor, and 906 control points for vacuum system (see Table 2).

Table 2: Statistic of control points

	Magnet power supply	Stepping Motor	Vacuum
ai	151	16	154
ao	135	--	--
bi	1387	--	558
bo	484	32	194
jsm	--	16	--
Total	2157	64	906

The presentation layer consists of a notebook PC, which runs a Linux operating system, since control environment was not available during the device commissioning. The notebook PC acts as an IOC booting server and an OPI console. IOC downloads vxWorks kernel, EPICS IOC core, and run-time databases from the booting server. Both Java and MEDM applications run on the same Linux PC.

SUMMARY

The devices have been commissioned for the L3BT control system, including magnet power supply, stepping motor for scraper, and vacuum system. The system has been verified including software and hardware functionality, remote controllability, and cable connection.

All components have been integrated successfully, including the core software for IOC, the EPICS run-time database, and the remote OPI. The design has been verified successfully to use a RDB server to manage machine signal and EPICS parameters, and generate an EPICS run-time database automatically.

A good experience has been obtained during the device commissioning. It is important for the whole J-PARC project, not only the L3BT. Many components can also be used in the other part.

ACKNOWLEDGEMENT

The authors would like to express their thanks to Mr. Yasushi Terashima of AKT Service Corporation for developing the EPICS driver for VME-bus based IO module and PLC.

REFERENCES

- [1] Y. Yamazaki (eds), "Accelerator Technical Design Report for J-PARC", KEK-Report 2002-13; JAERI Tech 2003-044, March 2003.
- [2] Y. Yamazaki, "The JAERI-KEK Joint Project for the High-Intensity Proton Accelerator, J-PARC", Proc. PAC 2003, May, 2003, Portland, p.576-580.T.
- [3] T. Ohkawa et al, "Design of the beam transportation line from the LINAC to the 3-GeV RCS for J-PARC" Proc. EPAC2004, Lucerne, July 2004, p.1342.
- [4] <http://www.aps.anl.gov/epics>
- [5] K. Watanabe et al, "Device information management system for J-PARC", this conference
- [6] H. Sako et al, "RDB system in J-PARC LINAC and its application to commissioning (II)", this conference