

# HIGH POWER TEST OF SINGLE CELL CAVITIES FOR SPRING-8

Hiroyasu EGO, Masahiro HARA, Koji INOUE, Yoshitaka KAWASHIMA,  
Yuji OHASHI, Hiromitsu SUZUKI, Isao TAKESHITA and Hiroto YONEHARA

JAERI-RIKEN SPring-8 Project Team  
2-28-2 Honkomagome, Bunkyo-ku, Tokyo 113 JAPAN

## ABSTRACT

The performance of two single cell bell shaped cavities fabricated by different procedures were studied at high RF power operation for the storage ring of SPring-8. Obtained data on cavities are presented in this report.

## 1. INTRODUCTION

The SPring-8 synchrotron radiation facility is just under construction in Hyogo prefecture and expected to be a high brilliant X-ray source. The RF components for the booster synchrotron and the storage ring have been tested at low and high RF power operation from the beginning of 1991 at RIKEN. We have already reported the performance of a five cell cavity for the synchrotron [1] using a 1MW CW klystron, its high voltage equipment and a 300 kW input coupler which were developed for TRISTAN main ring at KEK [2]. Considering the beam loss due to the coupled-bunch instabilities, the bell shaped single cell structure of a standing wave type is found more favorable for the storage ring than a re-entrant structure by computations with the codes such as SUPERFISH [3] and MAX3D [4]. The transverse and longitudinal impedances of higher order modes (HOM) for the bell shape cavity are about twice smaller than those of the re-entrant cavity although the shunt impedance of the accelerating mode ( $TM_{010}$ ) is about 30% smaller than that of the re-entrant cavity. Then the bell shaped cavity has less contribution to the beam blowup by about a half.

Two prototype cavities were fabricated by different procedures, which were a diffusion bonding and an electron beam welding [5]. Both cavities were made of oxygen free high conductivity copper (OFHC). Their cross sections are shown in Fig.1. The type (a) was constructed by the diffusion bonding method using nine copper plates of 40 mm in thickness. On the other hand, in the type (b), two blocks were first shaped into the design form and then connected at the equator by the electron beam welding so as to suppress thermal displacement as small as possible. Fundamental parameters calculated on the bell shaped single cell cavity are listed in Table 1.

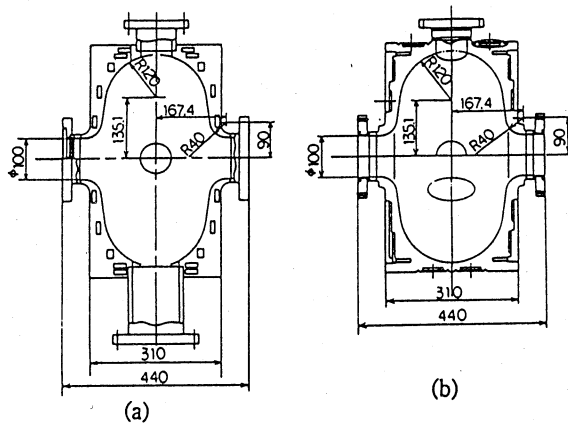

mode	frequency (MHz)	unloaded Q	shunt impedance Z(MΩ, MΩ/m)
TM <sub>010</sub>	508	47200	7.34
TM <sub>011</sub>	905	46500	2.98
TM <sub>110</sub>	761	52600	10.6
TM <sub>111</sub>	1076	43900	13.8

Fig.1 Cross-Sections of two prototype cavities which were made through different processes; type (a) was made with diffusion bonding method, type (b) was constructed by electron beam welding method.

Table1. List of fundamental and some higher order modes (calculation)

## 2. PRELIMINARY TESTS

Cavities were covered with mantle heaters for bake out. The change of Q-factor and coupling coefficient versus cavity temperature were measured and the results are shown in Fig.2.

Temperature rise of the inner surface was calculated to be 22 °C under the condition in water feed of 1.5 m/sec. The Q-factor is expected to become 5% worse at 100 kW RF power operation. After baking at 150 °C for 24 hours, cavity pressure attained  $5.6 \times 10^{-10}$  Torr using a 140 l/sec spatter ion pump. No difference depending upon the fabrication procedures was observed.

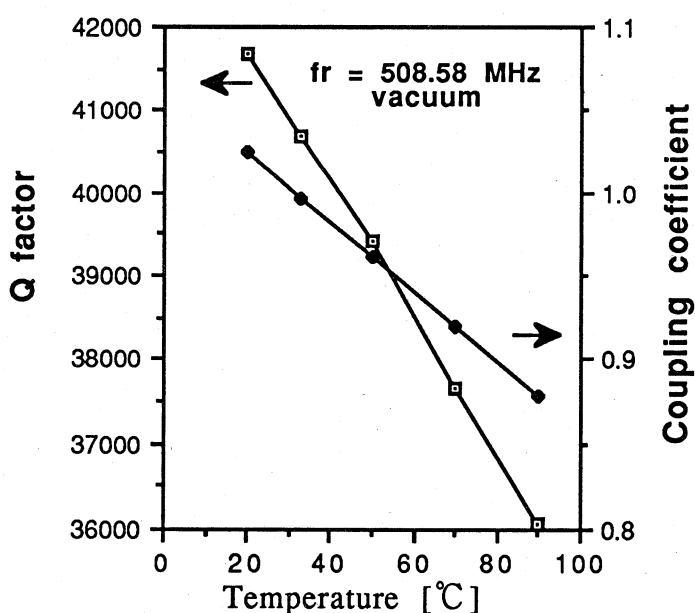

Fig.2 Relations of Q-factor and coupling coefficient versus temperature of a cavity. The solid lines are eye fits to the data.

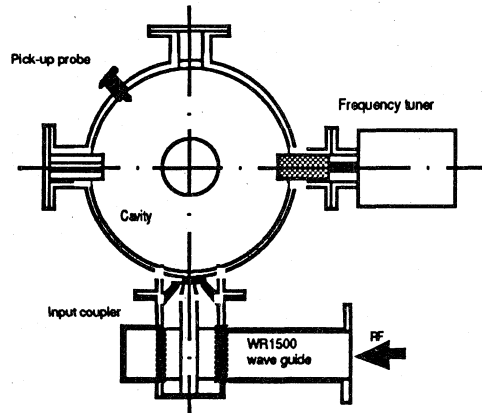

Fig.3 Cross-section with fully assembled units for high power operation

### 3.THE EXPERIMENTAL SET-UP AND RESULTS

The experimental set up for the high power test is shown in Fig.3. An RF power from the klystron couples into the cavity by the loop input coupler. The coupling coefficient is set to the critical coupling. The cavity has three plunger ports. A tuner plunger attached to one of them is used to adjust the resonant frequency (508.58MHz). This tuner has a stroke of 70 mm which corresponds to the frequency range of 2.5 MHz. Blank flanges are fixed on the other ports and changing their lengths is effective method to shift the HOM frequencies of coupled-bunch instabilities [6]. The RF power up to 150 kW has put into the cavity without any serious troubles. At 100 kW power operation which is the normal accelerating operation, the accelerating voltage without beam loading is estimated to be 770 kV and then the pressure was  $2.3 \times 10^{-7}$  Torr with a 200 l/sec turbo molecular pump.

### 4.AKNOWLEDGEMENT

We are indebted to staffs of KEK taking parts in RF section, in particular Profs. Y.Yamazaki and M.Ono for many useful suggestions and comments.

### 5.REFERENCES

- [1] H.Suzuki, T.Kojyo, H.Yonehara, Y.Kawashima, Y.Ohashi, K.Inoue, M.Hara and T.Yoshiyuki, Proc. of the 8th Symp. on Accel. Scien. and Tech.,113 Japan (1991)
- [2] M.Akemoto and Y.Yamazaki, Proc.7th Symp.Accel.Sci.and Tech.,106 Japan (1989)
- [3] K.Halbach and R.F.Holsinger, Particle Accelerators, 213, 7 (1976)
- [4] M.Hara, T.Wada, K.Mitomori and F.Kikuchi, RIKEN Accel.Prog.Rep.,199,20 (1986)
- [5] K.Inoue, T.Nakamura, Y.Kawashima and M.Hara, IEEE Par.Acc.Conf., San Francisco 667 (1991)
- [6] H.Kobayakawa, M.Izawa, S.Sakanaka and S.Tokumoto, Rev.Sci.Instrum.60 (7), July 1989