

PROGRESS STATUS OF STF ACCELERATOR DEVELOPMENT FOR ILC

Hitoshi Hayano, and STF group

High Energy Accelerator Research Organization (KEK), Tsukuba, Japan

Abstract

The superconducting RF test facility (STF) in KEK is the facility for developing superconducting Linac technologies of the International Linear Collider (ILC). The STF accelerator is a test accelerator composed of a normal conducting photocathode RF gun, superconducting cavities and cryomodules. In 2016, the selected 8 cavities in the 12m-cryomodule and the 6m-cryomodule were combined by the waveguide system, and tested the accelerating gradient with 2K cold state. The achieved 30.5MV/m average gradient for total 8 cavities was obtained. In parallel, the MARX modulator for the multi-beam-klystron was also developed and tested, and is under improvement of pulse voltage flatness with 5MW klystron connection. In the framework of US-Japan collaboration, cost-down studies on superconducting cavities and superconductor materials aiming for more high gradient, are just started between KEK and FNAL. These recent new studies of the STF accelerator are summarized and discussed in this paper.

1 INTRODUCTION

In the program STF-phase-2, the purpose of construction and operation of STF accelerator is to demonstrate the ILC Main Linac superconducting accelerator technology and to experience operation of high current and high beam power acceleration. During STF accelerator construction and installation in the STF-phase-2 program starting from 2009, we conducted several experiments, such as S1-Global cryomodule experiment [1], and Quantum-beam experiment for a compact high-flux X-ray generation [2]. A part of the Quantum Beam accelerator is still maintained and is used as the STF accelerator injector. The main accelerator by the

long cryomodule and short cryomodule were constructed from 2013, assembled into the STF tunnel in 2014. Two times of the cool-down

test of these new cryomodules were performed in 2014 and 2015.

The powering scheme of cryomodule is aiming to use TDR (Technical Design Report [3]) system which is using 10MW multi-beam-klystron and 120kV Marx modulator, supplying the RF power to 39 cavities with flexible dividing ratio. The demonstration of the TDR RF scheme is one of milestone of the STF accelerator construction and operation. The gradient performance of the cavities in the newly installed cryomodule were tested each by each using single waveguide system during cooled state. In 2016, the waveguide system which distribute RF power into 8 cavities with flexible amplitude and phase control was developed and installed. Also heat load improvement of the SC quadrupole magnet was done in 2016.

2 STF ACCELERATOR

The injector part of the STF accelerator consists of Cs-Te photo-cathode RF gun (1.3GHz DESY/FNAL design normal conducting gun cavity), and the capture cryomodule. The RF gun is operated by 5MW pulsed klystron, with around 3MW RF power input. The energy of gun output beam is around 4MeV. Two 9-cell superconducting cavities in the capture cryomodule were tested and successfully reached its gradient up to 40MV/m and 32MV/m. The operation is done with 16MV/m and 24MV/m, for 40MeV accelerated beam energy. They are powered by 800kW pulsed klystron (DLDS klystron). The downstream of the injector includes ILC-type cryomodule, CM-1, and, the



Figure 1: Tunnel view of the STF accelerator. The RF power distribution system is installed in the right side of capture cryomodule, CM-1 and CM-2a. Vector sum field control was demonstrated for 8 cavities combined.

half-size cryomodule, CM-2a, connecting beam lines and the beam dump. So far, beam lines and beam dump are not installed yet. View of the current STF accelerator is shown in Figure 1 [4].

The accelerator in plan will include two stage bunch compressors for future FEL application. The first stage bunch compressor is a chicane at the entrance of CM-1. The second stage compressor is a chicane in front of the downstream beam dump. For undulators and user area of FEL, the tunnel is necessary to be expanded 100m more length to the downstream. The connecting beam line is under design, not yet installed. The 2K cold-boxes for 2K liquid helium supply liquid-helium to CM-1 and CM-2a is installed at the front of CM-1, the left-wall-side.

The RF power distribution system are now installed in the side of the cryomodules, however only for selected 8 cavities. The accelerated beam energy will be 418MeV, assuming 31.5MV/m gradient for 12 cavities in CM-1 and CM-2a, and 40MeV energy at the exit of the capture cryomodule. The accelerating beam train length is 0.9ms with 5.7mA peak intensity and 2.7MHz bunch repetition in a train with 5Hz train repetition, which are met with ILC beam specification.

3 CRYOMODULE PERFORMANCE

3.1 Superconducting Cavities

Total number of the cavities used for the STF accelerator was 14, while 15 cavities were fabricated and tested in the vertical cryostat. They are 2 for the capture cryomodule, 8 for CM-1, and 4 for CM-2a. The left one cavity is a spare cavity. In STF, the inner surface treatment and the field test were allowed maximum 4 set of treatment and field test. The summary of the final gradient performance is shown in Figure 2 of blue bars. The average gradient in the final field test was 34.2MV/m. The maximum gradient was 41MV/m and the minimum gradient was 12MV/m.

They were tested the gradient performance in the cryomodule in October 2015. Red bars for 600us RF pulse width performance, and green bars are for 1500us RF pulse

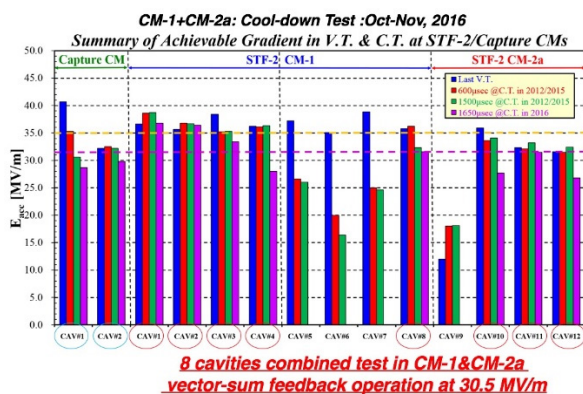

Figure 2: The cavity gradient performance result during cool-down. Blue bars show the performance at vertical test. Red bars and green bars show at the cryomodule test with short (600us) RF pulse and full-length (1500us) RF pulse. The green bars are the performance of 2016 test.

width performance. The performance degradation happened to three cavities in CM-1, and seemed to come from the failure of the cryomodule assembly procedure. The purple bars in Figure 2 shows the gradient performance at 1.65ms full-top pulse in 2016 cool-down test. The selected 8 cavities in CM-1 and CM-2a and a pair of two cavities in capture cryomodule, were connected the high power RF distribution and tested the digital feedback with vector sum of the pickup signals. Details are in Section 4.

3.2 Superconducting Quadrupole Magnet

The CM-1 includes a conduction-cooled splittable superconducting quadrupole magnet together with a beam position monitor in the cryomodule center position. The magnet uses conduction cooled, splittable structure, which are newly introduced concept in TDR. The fabrication of the conduction-cooled quadrupole magnet by the collaboration with FNAL was done.

In the first cool-down test of 2014, the conduction cooled splittable quadrupole magnet was cooled only at 9K, while the target temperature was 5K. The reason was analysed after warm-up, and was to be insufficient thermal anchor or thermal shield for incoming heat from the current leads. The modification to improve thermal shield from current lead was done during 2015 spring to summer time, introducing several thermal anchors and HTS (High-Temperature-Superconductor) leads. However the heat leak was not improved much. In spring to summer 2016, the connection quality of thermal anchors were improved more, before 2016 cool-down test, as shown in Figure 3.

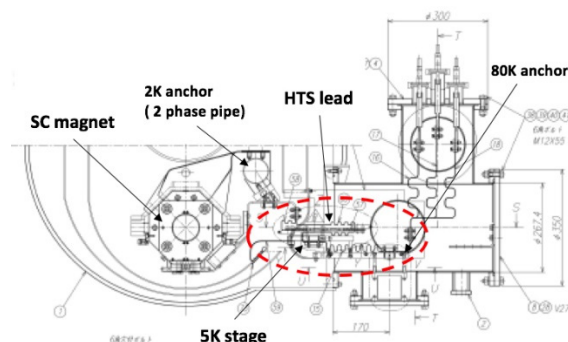

Figure 3: Heat leak from current lead was improved by thermal anchor connection tightening and changing the materials of thermal anchors. The red circle shows improved position.

In the cool-down test on October 2016, the coil temperature was 7.5K, which was 0.4K increase from the case of 2015 test. However heat load to the current leads input side were improved much. Current excitation went up to 50A which is the specification of the quadrupole magnet. The quench location of splice between coil-1 and coil-2 inside magnet was not a problem in this test. Current excitation/decrease speed was 1A/s, as shown in Figure 4. Inductance of the coils estimated from voltage by current change was 6mH, which is consistent with the design value.

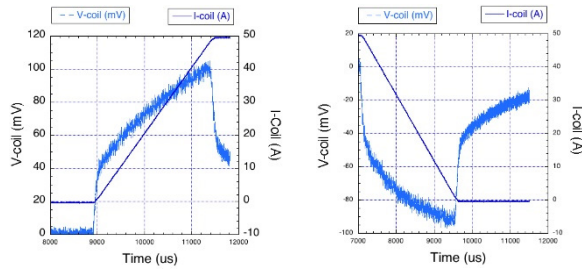

Figure 4: Left: magnet excitation upto 50A with the current increase speed of 1A/s. Induced voltage is also plotted. Right: magnet excitation release from 50A to 0A with the current speed of 1A/s. Induced voltage is also plotted.

4 RF POWER DISTRIBUTION AND VECTOR-SUM LLRF

The RF power distribution scheme with control of power dividing ratio and phase is adopted as a cost effective baseline of TDR. The TDR RF power source consist of a 10MW multi-beam klystron (MBK), a Marx modulator, and waveguide system which distributes 1.3GHz 1.6ms pulse RF power into 39 cavities with circulator in each cavity input. In order to supply RF power effectively to the cavities which have 20% spread of gradient performance, the power can be split with flexibility by a variable hybrid (Pk control). Also, a phase of RF input can be controlled by a phase shifter in each of cavity input line. A coupling of cavity (Loaded-Q, QL) can be controlled by an input coupler insertion length. In order to control each cavity power input and Loaded-Q of each cavity among vector-sum controlled cavities, the above variable adjustment (Pk-QL control) are controlled remotely. Figure 5 scheme shows detail view of this waveguide system design for STF cryomodules. The realization of the design was done by building the waveguides in the support frame, as shown in Figure 6.

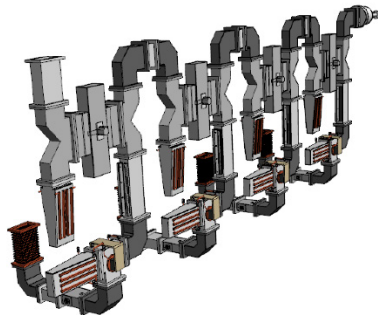

Figure 5: Design of RF power distribution scheme for 4 cavities of STF phase-2 cryomodule, according to TDR design.

Figure 7 shows a scheme of the LLRF control board configuration. The two boards having 8 ADC in each are connected by optical link. The main board receive 8 cavity pickup signals. The other board receive 4 cavity pickup

signals. However only 8 cavities are powered, so only 8 cavity signals are put into ADCs. Converted cavity pickup signals are collected into the main board and made vector sum, and then fed back into the klystron input for stabilization feedback control.



Figure 6: Realized RF power distribution scheme of STF phase-2 cryomodule. The waveguide components are built in the support frame.

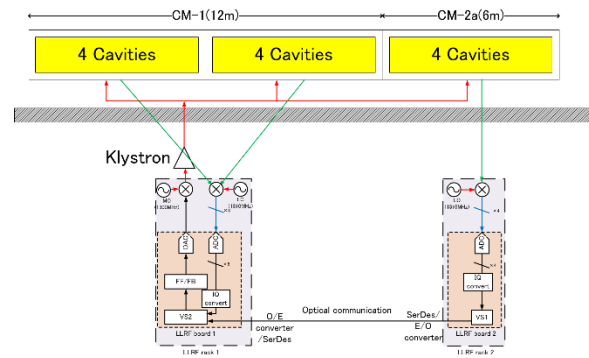

Figure 7: LLRF control board MTCA.4 are connected by optical link to make vector sum calculation digitally for 8 cavities pickup signals.

Figure 8 is the results of digital feedback control for 8 cavities vector sum using the optical link connection. The amplitude stability was 0.006%rms for 723us RF flat-top. The phase stability was 0.03degree-rms for the same flat-top. They are well within the specification of ILC-TDR stability.

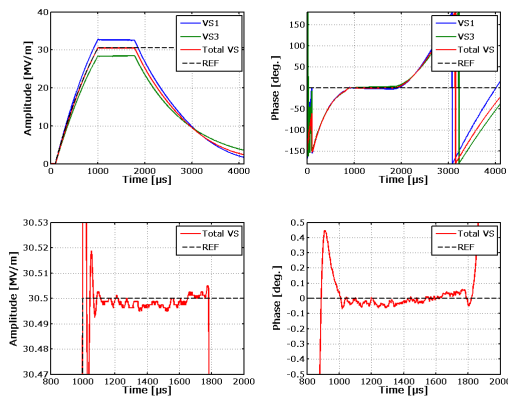

Figure 8: LLRF control system to combine 8 cavities pickup signal is tested. The vector sum control of flat-top RF amplitude (left) and phase (right) are shown. The upper row are for overall waveforms and the lower row are the expanded view of the flat-top region.

5 MARX MODULATOR DEVELOPMENT

As a cost-effective, compact klystron modulator with good maintainability, Marx-type modulator was selected in TDR. STF began to develop Marx modulator to be used in the STF phase-2 program. The new design consists of 20 units of MARX cell which include 4 charging/switching blocks. Each switching block controlled by flexible switch timing to accommodate pulse width control for the output voltage sagging compensation. The single unit test and the 20 unit combined test were performed using load resistance. With connection of 5MW klystron as a load (Figure 9), 82kV with 48A at the flat-top was attained in 2017, as shown in Figure 10. There is still break-down problems in the MARX cell unit. The improvement of the MARX unit is undergoing.

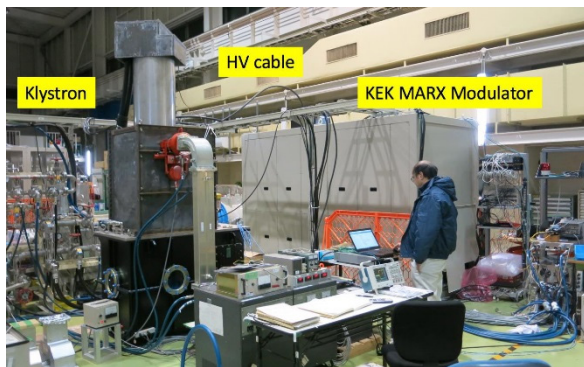

Figure 9: picture of Marx modulator and 5MW klystron connected under testing at STF.

6 US-JAPAN COST-DOWN STUDIES

The cost down of superconducting accelerator is a main concern of ILC. Recently DOE of US and MEXT of Japan agreed to pursue the cost down study. We proposed the following items;
For short term study

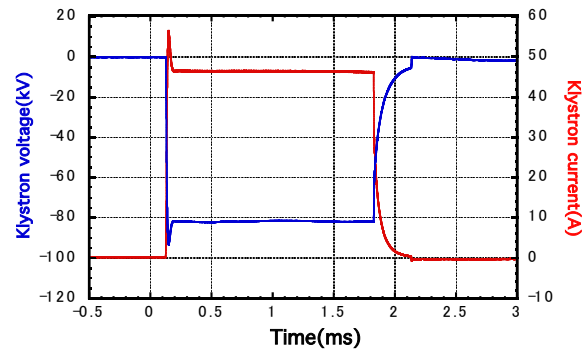

Figure 10: Waveform of Marx modulator with 5MW klystron. Blue shows voltage, Red shows current. They are 82kV 48A at 1.65ms flat-top.

- (A-1)Nb ingot slicing for cavity materials.
- (A-2)High-Q and High-gradient cavity by N-infusion process.
- (A-3)New ceramics for Input coupler
- (A-4)New cost-down EP technology
- For long term
- (B-1)Multilayer-thin-film coating on a cavity for more high gradient
- (B-2)Hydroforming technology development for cavity fabrication.

So far, DOE and MEXT gave a priority to (A-1) and (A-2) for the moment. The study budget will be available in the fiscal year 2018.

ACKNOWLEDGEMENT

The author would like to thank all the members of STF group for their effort to develop ILC superconducting accelerator technology. The support of the LC supervisor, S. Michizono, and the support of Accelerator Laboratory director, S. Yamaguchi, trustee of the executive board, Y. Okada, and director general of KEK, M. Yamauchi, are gratefully appreciated.

REFERENCE

- [1] Hitoshi Hayano *et al.*, "Results Achieved by the S1-Global Collaboration for ILC," Proc. of the 26th International Linear Accelerator Conference, Tel-Aviv, Sep. 2012.
- [2] Hiroataka Shimizu *et al.*, "X-ray Generation by Inverse Compton Scattering at the Superconducting RF Test Facility," submitted to N.I.M. A.
- [3] ILC Technical Design Report; <http://www.linearcollider.org/ILC/Publications/Technical-Design-Report>
- [4] H. Hayano, "Superconducting Accelerator Development at STF for ILC", Proc. of The 13th annual Meeting of Particle Accelerator Society of Japan, Makuhari, August 2016.