

500MHz THREE CELL SUPERCONDUCTING CAVITY

Takaaki FURUYA, Kazufumi HARA, Kenji HOSOYAMA, Yuzo KOJIMA, Shinji MITSUNOBU,
Shuichi NOGUCHI, Toshiharu NAKAZATO and Kenji SAITO
National Laboratory for High Energy Physics
Oho-machi, Tsukuba-gun, Ibaraki-ken, Japan

INTRODUCTION

At KEK, 500 MHz superconducting niobium cavities have been developed^{1,2}. For the purpose of demonstrating the feasibility of superconducting cavity in TRISTAN, a three cell structure has been built and measured. The Q-value of 1.4×10^9 at low field and 0.4×10^9 at field gradient of 5.2 MV/m were obtained in the laboratory test.

This cavity was installed into TRISTAN Accumulation Ring (AR)³. At the beam test, field gradient of 4.3 MV/m was obtained and heat loss of 37 Watts were measured at 3.7 MV/m.

The field gradient in the laboratory test was limited by available rf power and by heating of the input coupler at the beam test. In this paper, the fabrication and measured performance of the cavity are reported.

CAVITY

Design

As is shown in Fig.1, each cell of the structure has spherical shape⁴ to avoid electron multipacting, and tilted end plates of 80° in order to getting good flow of acid and water during surface treatments. An elliptical cross section of 30 mm x 60 mm is selected for irises in order to decrease the ratio of E_{sp}/E_{acc} . The flatness of the accelerating field distribution is accomplished by making a diameter of both apertures larger and shortening the length of end cells by 0.88 mm. An input coupler is set on the center cell, a pair of HOM coupler ports are prepared on the equator of each cell. Main parameters are listed in Table 1.

Table 1

The design parameters of the three cell cavity calculated by SUPERFISH.

Frequency	508.581 MHz
Effective length	884 mm
R/Q	389 Ω
Geometrical factor	266 Ω
Field strength	
Eacc	$22.3 \times \sqrt{PQ}$ V/m
Eap/Eacc	1.89
Esp/Eacc	1.86
Hsp/Eacc	39.6 Gauss/[MV/m]

Fabrication

In order to check the performance and frequency of each cell, three single cell cavities were fabricated and measured individually before building up the three cell structure. Each cavity consists of two half cells and an equatorial ring on which a pair of HOM coupler ports and small one for monitor coupler are extruded. For the center cell another port for input coupler is added to that ring.

All parts are formed by spinning method from 2.5 mm thick Nb sheets. After forming, two half cells, one of which is welded to the equatorial ring, are buffed, electropolished by 130 μm and assembled by electron beam welding. Three single cell cavities were annealed for 90 minutes at 900°C, and electropolished again by 30 μm. Two cycles of oxipolishing were performed also. Finally the cavities were rinsed with ultra pure water and filtered methanol.

Between 1st and 2nd cold test, each cavity was ground off the breakdown spot which was detected by carbon resistors fixed on the outer surface of the cavity. Pre-tuning of the resonant frequency was done in order to adjust to the design value.

The three cell structure was annealed at 900°C. For annealing, a carbon support structure was used not to deform the cavity. Electropolishing of 30 μm was performed in order to eliminate oxide created by EBW. The cavity was positioned vertically in the acid bath. A cathode was covered with teflon tubing which led hydrogen gas to outside of the cavity. Finally, oxipolishing and rinsing with ultra pure water and filtered methanol were made.

MEASUREMENTS

Single cell

The performance of the single cavities (L,C,R) is shown in Table 2 and Fig.2. Accelerating field beyond 5.5 MV/m was obtained for L and R-cell after grinding and re-treatment. The breakdown spot of the C-cell was ground off once more after 2nd cold test. The breakdown of all cells did not come from electron loading effects but from localized heating at the welding seam. All coupler ports did not show any heating, which were closed by niobium flanges.

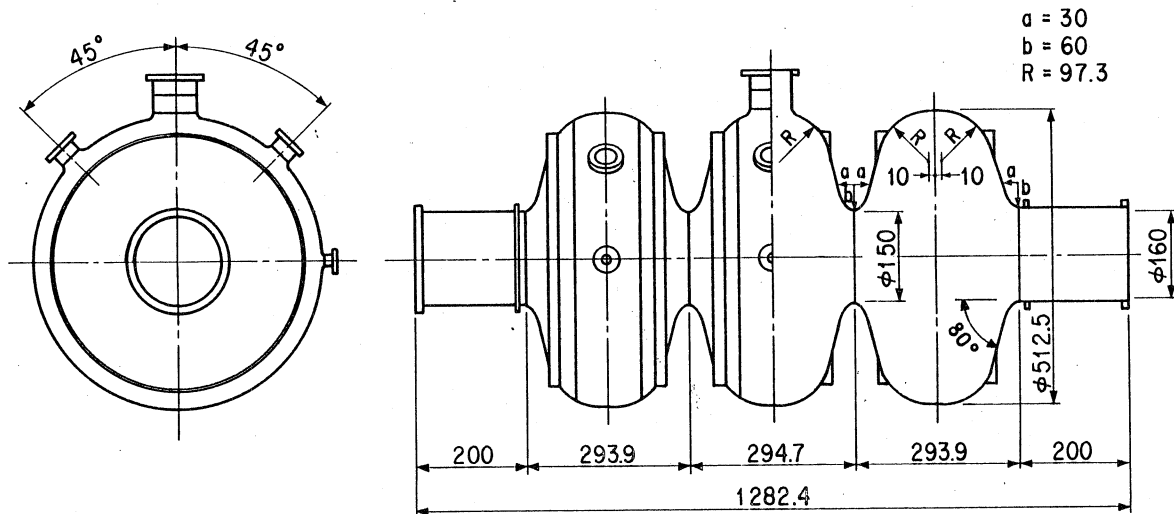

Fig.1. Layout of the three cell structure.

Table 2

The performance of the single cell cavities.

Cell No.	1st meas.	2nd meas.
L-cell		
Freq. [MHz]	507.253	507.297
Max. Eacc [MV/m]	4.5	5.7
Max. Q ₀ [x10 ⁹]	3.1	2.9
C-cell		
Freq. [MHz]	506.027	506.092
Max. Eacc [MV/m]	4.1	4.8
Max. Q ₀ [x10 ⁹]	2.9	3.1
R-cell		
Freq. [MHz]	506.794	507.283
Max. Eacc [MV/m]	4.6	5.6
Max. Q ₀ [x10 ⁹]	2.9	3.4

No beam test

The three cell structure were measured in a vertical cryostat before the beam test. Results are shown in Fig.2. Field gradient of 5.2 MV/m were obtained without breakdown. It was limited by available rf power. The Q-value at this field level was 0.4 x 10⁹, which corresponded to the cavity loss of 130 Watts.

The Q-value measured in vertical test decreased about a half of the value that was obtained in the single cell cavity measurements. This degradation may come from the final electropolishing. Because of large surface area many hydrogen bubbles were generated, the teflon tubing could not shield them sufficiently. After final electropolishing, some traces have been left on the cavity surface.

The difference of the resonant frequency from the design value was 40 kHz, which needed to extend the total cavity length by 0.3 mm. This quantity is in the range of a mechanical tuning system. The output power of the pick up probes mounted to each cell showed no change of the field distribution after cooling down the cavity.

The Q-value of 1/2-π-mode and 0-mode at low field level were 1.4 x 10⁹ and 1.0 x 10⁹ respectively.

Beam test

The cavity was operated twice in AR. The 1st test was stopped by vacuum leak at the input coupler. Dirty air got into the cavity together with helium gas, water condensed on the bottom of the center cell and copper sputtered onto the inside surface of the port. The copper was removed in hot H₂SO₄, and subsequent HF rinse was made.

The external Q of the input coupler was 2.2 x 10⁶ and 1.3 x 10⁷ in the 1st and 2nd tests respectively. The Q-value was measured by consumption of liq.He at several field levels as shown in Fig.2. The Q-value of the cavity did not change before and after the vacuum leak. At the end of 2nd test, it was tried to reach the breakdown field, but stopped at the level of 4.3 MV/m by liq.He boiling. Thermocouples and carbon resistors indicated the heating of the input coupler.

Pressure dependence of the frequency was -56 Hz/mbar. The piezo tuners could stabilize the resonant frequency.

Synchrotron radiation and residual gases in AR did not affect the cavity performance during the beam test.

Table 3

The measured performance of the three cell cavity.

Operating temperature	4.2 K
Range of tuning	
coarse	±200 kHz
fine	±1 kHz
Maximum Eacc	
laboratory test	>5.2 MV/m
beam test	4.3 MV/m
Q ₀	
at low Eacc	1.4 x 10 ⁹
at Eacc=3.7MV/m	0.8 x 10 ⁹

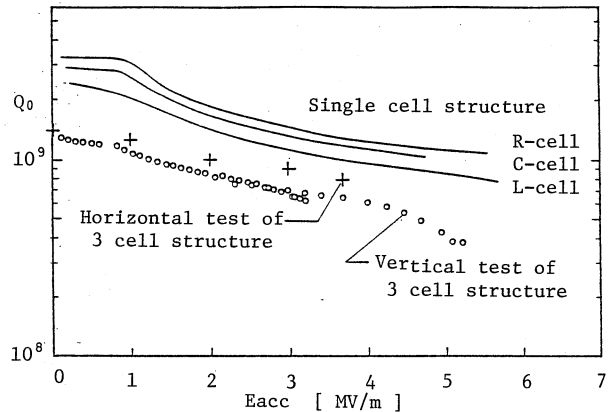

Fig.2 Q₀ vs. Eacc. The Q₀-value of the horizontal test was obtained from liq.He consumption.

CONCLUSION

A three cell superconducting cavity was installed and tested successfully in AR. The measured performance is listed in Table 3. Accelerating field up to 4.3 MV/m was obtained. The electron current of 10 mA was stored at 2.5 GeV, and current of 1 mA was accelerated up to 5 GeV. The performance of the cavity has not changed during the beam test. Rather low Q-value of the cavity may come from a problem in final electropolishing process, an improvement on the process remains as a next problem, as well as the input coupler.

ACKNOWLEDGEMENT

We wish to express our thanks to the members of the machine shop, operation, vacuum, and rf group for their support during fabrication and beam test.

REFERENCES

1. T.Furuya, S.Hiramatsu, T.Nakazato, T.Kato, P.Kneisel, Y.Kojima and A.Takagi, IEEE Trans.Nucl.Sci. **NS-28** No.3(1981)3255.
2. Y.Kojima, T.Furuya and T.Nakazato, Jpn.J.Appl.Phys. **21**,No.2(1982)L86.
3. Y.Kojima, Proc.2nd Workshop on RF Superconductivity (CERN,July,1984).
4. U.Klein and D.Proch, Proc.Conf.on Future Possibilities for Electron Accelerators, Charlottesville, Va.1979.

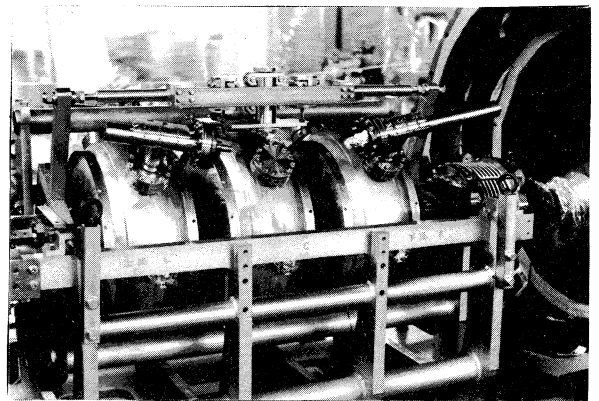

Fig.3. The three cell cavity with HOM couplers and a horizontal cryostat for the beam test.