

## Improvement of $\pi 2$ Beam Line Control

Y.Suzuki, M.Takasaki, M.Minakawa, H.Ishii,  
Y.Kato, M.Ieiri, K.H.Tanaka, H.Noumi,  
and Y.Yamanoi

KEK National Laboratory for High Energy Physics  
1-1 Oho, Tsukuba, Ibaraki 305, Japan

### Abstract

This paper reports the latest improvement of  $\pi 2$  beam line control. The  $\pi 2$  beam line has eight sets of magnet and magnet power supply. On this improvement, a microcomputer had embedded in each of the power supplies. The microcomputer operates the power supply, watches the condition, and sends more details to a control computer of the beam line through GPIB (IEEE-488) high way. As the results, the control computer has released from operation and surveillance of the power supplies, and the maintenance work has become more efficient.

### I. INTRODUCTION

At first, we review the old control systems of  $\pi 2$  beam line, and make clear what system is better for the beam line control. After this section, a power supply controller, the function of the power supply controller, and the control system of  $\pi 2$  beam line are described in section II, III, and IV respectively.

Now at the KEK 12 GeV proton synchrotron (KEK-PS), there are more than 150 sets of magnet and magnet power supply in two experimental halls (North counter hall and East counter hall).

Since the KEK-PS was commission in 1976,  $\pi 2$  beam line has been used for many experiments as the oldest beam line in the East counter hall. The beam line has been continuously operated for two or three weeks running and for three days stop. In this operation schedule, on the three days, the magnets, the magnet power supplies, and other devices in many beam lines have to be maintained. But those pressing work became available to do efficiently in a short time by the improvement of control systems.

About 17 years ago,  $\pi 2$  beam line was constructed. The control system of the magnet power supplies was that the control panel and rack was connected directly to power supplies. Through this control system, it took much time to check up magnets and magnet power supplies. For example, the process of the check up is listed below:

- 1) at the control panel of the beam line, select a magnet power supply by multiplexer switch;
- 2) press check(reset)-switch, check fault indication lamps;
- 3) turn on power switch, check the ON lamp light;
- 4) check the output current to be 0 ampere or not;
- 5) set the output current by push-button switch. It takes about two and half minutes;
- 6) check the stability of the output current by digital meter;
- 7) set the current to 0 ampere, and turn off the power supply.

It took about six minute with quick operation to check up one power supply.

Another weak point of this control system is that, in the counter hall, the experimental area and beam lines are occasionally rearranged, but the control panel and rack is not so easy to move here or there.

Next system consisted of a personal computer, interface devices, and a CRT terminal. On this system, the power supplies were the same as before, then the same signal cables were connected to the interface devices. But the operation ability of the beam line was noticeably improved, and it afforded satisfaction that the CRT terminal could be removed with ease. Then the check up work of the magnets and the power supplies was done in a short time, and a schedule for maintenance work of beam lines could be laid out effectively. But there were a few dissatisfactions. They are listed below:

- 1) increase of the devices which require check up;
- 2) increase of difficulty to point out a trouble part on the control system. Especially, the interface devices are not easy to check, and it takes two staff, or need one staff and a special tool or another computer for testing them;
- 3) at the rearrangement of beam lines, the control cables between the interface devices and the power supplies are not easy to use again as resource, though the cost of cables is high;
- 4) by the increase in number of power supplies, the computer efficiency for control and surveillance is lowered.

## II. POWER SUPPLY CONTROLLER

As the solution of the above dissatisfactions, efforts were concentrated upon to develop a power supply controller (PSC) as a part of magnet power supply rather than to introduce a higher performance computer or data highway. Fig. 1 shows the PSC.

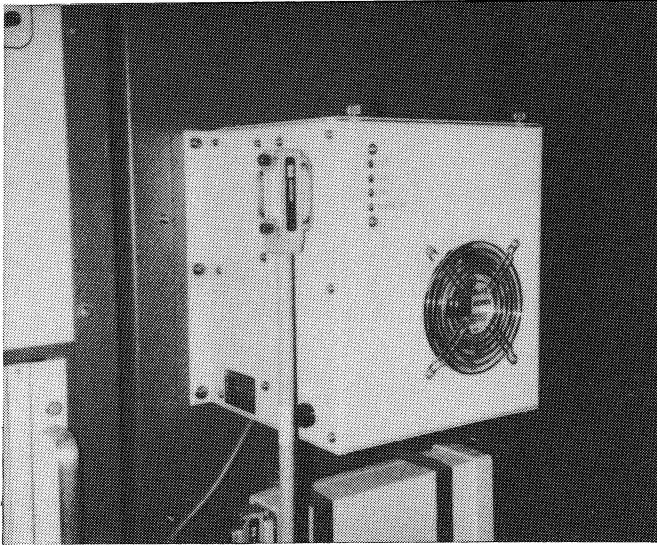

Fig. 1. Power supply controller.

The PSC consists of five boards (STD: IEEE-961) which have functions as listed below.

- (1) CPU board: Z-80 cpu and GPIB interface.
- (2) DAC board: 16-bit DAC for reference voltage.
- (3) ADC board: 16-bit ADC for monitoring the output current of magnet power supply.
- (4) ADC board: 12-bit ADC and 16-channel multiplexer. This board is used for monitoring the following values:
  - 1, reference voltage (16-bit DAC);
  - 2, dc output voltage;
  - 3, wave form of the output voltage;
  - 4, AC input current ;
  - 5, voltage of a point in the current control loop of magnet power supply;
  - 6, seven points on low-voltage power supplies.

(5) relay I/O board: for control and monitor of the following points.

Control points:

- 1, power switch ON/OFF;

- 2, reset of interlock circuit;
- 3, selection of polarity ;
- 4, selection of regulation mode (voltage /current);
- 5, selection of remote or local control;

monitoring points:

- 1, control power ON/OFF;
- 2, remote/ local;
- 3, power switch, ON/OFF;
- 4, polarity +/-;
- 5, magnet #1 ready/ trouble;
- 6, magnet #2 ready/ trouble;
- 7, fault; dc over current;
- 8, fault; dc current leak;
- 9, fault; over heat #1;
- 10, fault; over heat #2;
- 11, fault; cooling fan;
- 12, fault; magnet power supply's door open;
- 13, fault; magnet #1; over temperature;
- 14, fault; magnet #1; failure of cooling water flow.

## III. PSC AND MAGNET POWER SUPPLY

The soft program of the PSC was developed for reducing the load of beam line control computer, then all the operation of magnet power supply is done by the PSC.

The procedure of magnet power supply operation for a current setting message received is listed below:

Step-1, PSC receives a "A xxx.xx" current setting message from a beam line control computer.

-2, invoke the operation program of magnet power supply.

-3, check interlock fault signals.

-4, check low voltage power supplies, output current, and DAC output voltage.

-5, set the magnet power supply to current or voltage regulation mode.

-6, check polarity, and turn reversing switch.

-7, turn on power switch, and check its status.

-8, current setting.

-9, after current setting, send SRQ(service request : on this case this interrupt signal is used to report the end of current setting).

-10, set the limit values of the output current for watching program.

-11, watching and check status: ON/OFF, interlock signals, remote or local, output current, reference DAC, and low-voltage power supplies.

At this state, by a "A-xxx.xx" message which means to set current to negative xxx.xx ampere, the following steps are done:

- 12, current setting starts to 0 [A].
- 13, turn off power switch: OFF.
- 14, jump to the above step 2.
- 15, the final state has negative output current: (-) xxx.xx ampere

At this state, by a "V+ xx.x" message, the following steps are done.

- 16, current setting starts -xxx.xx[A] to 0 [A].
- 17, turn off power switch.
- 18, jump to above step 2. and the final state has positive output voltage; (+) xx.x volt.

At the OFF state, by "CK" message:(check), the following steps are done.

- 19, reset interlock circuit, check fault signals.
- 20, check the output voltages of low-voltage power supplies, DAC, and output current.
- 21, turn reversing switch, check its status.
- 22, turn on power switch, check its status.
- 23, check the output voltages of low-voltage power supplies, DAC, and output current.
- 24, turn off power switch, check its status.
- 25, send SRQ signal to indicate the check-end.

By the above PSC operation, the computer of the beam line control is released from the each operation of magnet power supplies. Therefore, the efficiency of the computer is not lowered by the increase in number of magnet power supplies.

On this system, at a trouble of magnet power supplies, the PSC makes a report as words which indicates clearly what trouble is occurred, and what electric part is needed for the maintenance. It greatly helps for the maintenance staff.

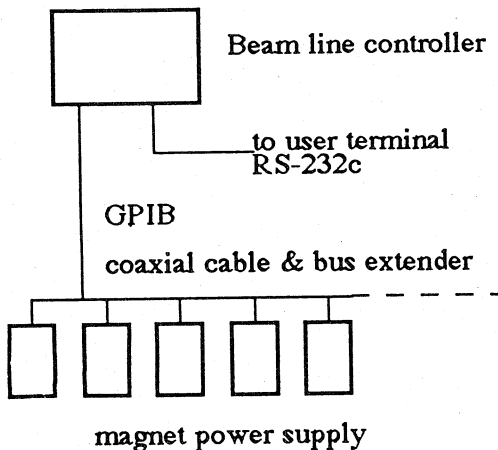

Fig. 2.  $\pi 2$  beam line control system.

#### IV. CONTROL SYSTEM OF $\pi 2$ BEAM LINE

At the improvement of  $\pi 2$  control system, the PSC was installed in each of eight magnet power supplies of  $\pi 2$  beam line, and those PSCs and a computer for the beam line control were connected by a single GPIB high way: coaxial cable.

The computer is HP9000-300: personal computer with BASIC language. The GP-IB was extended by GP-IB extender: HP-37204A. The soft program for the beam line control was written by BASIC language.

The construction work of this new control system of  $\pi 2$  beam line had done with ease during the two months in the summer shut down of 1992. At the construction of control wiring, the cost and the period of time was lowered into the minimum by GPIB high way.

Since the control system has been used for not only usual operation but check up work usefully.

The computer has showed sufficient performance, and the GPIB high way has too. But the reason of the good performance is mainly due to the PSCs. The computer and the GP-IB high way are almost in idle state, though the PSCs are always operating and watching the magnet power supplies on the system.

#### V. CONCLUSION

By introducing of the magnet power supplies with PSC, the control system has given the results, not only good performance than the before, but also rationalization in the construction and the maintenance of beam lines. It has reduced costs, manpower, and time.

At present, there is a plan to set up one more magnet power supply (with PSC) in  $\pi 2$  beam line, and the extension work of the control system is expected to be completed with ease and in a short period of time.