

Design of an Undulator at DSR of RIKEN RI Beam Factory

Masanori WAKASUGI and Takeshi KATAYAMA*

RIKEN, The Institute of Physical and Chemical Research, Wako, Saitama 351-01, Japan

*Center for Nuclear Study, School of Science, University of Tokyo, Tanashi, Tokyo 188, Japan

Abstract

According to requirements from the X-ray - RI collision experiment at DSR that is proposed in the RIKEN RI beam factory project, an undulator for elliptically polarized X ray was designed. An Apple-II type of the undulator was adopted so that both the X-ray energy and the polarization are continuously changed at the same time. The photon flux of more than 10^{15} photons/(s 0.1%b.w.) is calculated for any polarization in the energy range of 30 - 800 eV.

1 Introduction

In the RIKEN RI beam factory project, we will construct not only the heavy ion machines but also the electron machines. [1,2] The coexistence of both machines allow us to make new type of the collision experiments. One of them is the X-ray - RI collision experiment. Using high brilliant synchrotron radiation from one of the DSR ring in which electron beam is stored, we make high resolution X-ray spectroscopy of highly charged RI beam stored in another ring of the DSR. [3] This experiment requires following specifications on the X ray. The X-ray energy is 30 - 800 eV, it can be continuously scanned with the step of less than 0.1 eV. Any polarization of the X ray can be chosen. The polarization should be kept during the energy scanning. The X-ray beam intensity is as large as possible, and the energy resolution is also as high as possible. To get the X ray beam intensity of more than 10^{12} photons/(s 0.01%b.w.) at the colliding section, output photon flux from the undulator has to be more than 10^{15} photons/(s 0.1%b.w.).

2 Electron Beam in the DSR

The intensity and the resolution strongly depend on the quality of the electron beam in the DSR. To make

low emittance electron beam, DBA lattice is adopted in the arc section of the DSR [4]. As described in Ref. [3], the electron beam having the energy of 0.3 - 2.5 GeV is stored in the DSR. The calculated electron beam specifications are listed in Table 1. The average current is 0.5 A. The beam emittance is obtained to be $\epsilon_x/\epsilon_y = 7.8/13.9$ nmrads at the maximum energy of 2.5 GeV. Since the beta function value at the undulator section is about 5 m, the electron beam size at the undulator section is smaller than $\sigma_x/\sigma_y = 197/264$ μm .

3 Design of an Undulator

3.1 Magnetic Structure

Figure 1 shows the schematical view of the magnetic structure of an Apple-II type of the undulator recently proposed by Sasaki et al. [5]. This has two pairs of planer permanent magnet (Nd-Fe-B) arrays above and below the electron beam plane. The X-ray energy is scanned by changing the gap width. The polarization is changed by shifting the relative position of pairs of magnetic arrays. On-axis magnetic field produced by the phase shifting makes herical and sinusoidal motions of the electron beam. The magnetic field in horizontal and vertical directions are shown in Fig. 2 at three different phases. The linear polarizations in horizontal and vertical directions are obtained at the phase shifts $D = 0$ and $D = 1/2\lambda_u$, respectively, where λ_u is the length of a magnetic period. The circularly polarized X ray can be get at $D = 3/8\lambda_u$ as shown in the figure.

3.2 Gap Width and Length of a Period

The minimum gap width depends on the size of the vacuum tube inserted in the gap. Taking the vertical tube size of 15 mm, the 1-mm tube thickness and the 1-mm spacing between the tube nad magnet, the minimum gap width was decided to be 20 mm.

Table 1 The specification of the electron beam in the DSR.

	E_e	(GeV)	0.3	1	1.5	2	2.5
Radiation Loss	U	(keV/turn)	0.1	10.6	53.2	169.1	412.7
Emittance	ϵ_x	(n m rad)	0.11	1.24	2.8	4.97	7.76
	ϵ_y	(n m rad)	0.2	2.22	5.01	8.92	13.9
Energy Resolution	$\Delta E_e/E_e$	(10^{-4})	0.82	2.7	4.1	5.5	6.9
Bunch Length	σ_z	(cm)	0.006	0.033	0.061	0.095	0.134
Dumping Time	τ_x	(sec)	6.2	0.17	0.05	0.02	0.01
	τ_y	(sec)	6.1	0.17	0.05	0.02	0.01
	τ_e	(sec)	3.1	0.17	0.03	0.01	0.005
Toushek Lifetime	τ	(10^6 sec)	0.008	0.16	8.1	180	2.7

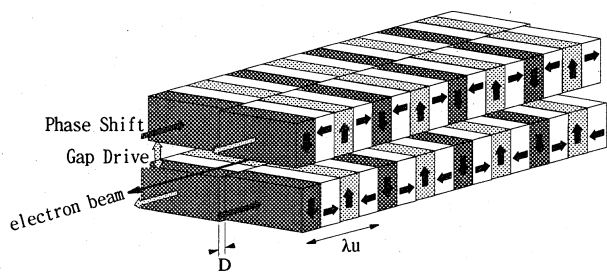

Fig. 1 Magnetic structure of the Apple-II type undulator.

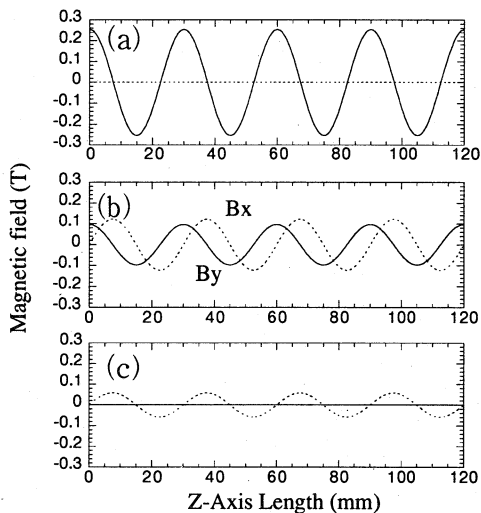

Fig. 2 Magnetic field on the electron beam axis. (a), (b) and (c) correspond to the phase shift of 0 mm, 11.25 mm and 15 mm, respectively.

The length of period is decided from the following considerations. The space of 6.7-m length is available for insertion devices in the DSR. The photon flux of more than 10^{15} photons/(s 0.1%b.w.) has to be obtained using the electron beam having the energy of more than 0.3 GeV and the gap width of more than 20 mm over the X-ray energy range of 30 - 800 eV. Thus the length of the period was decided to be 3 cm. In this case, the maximum K value is 0.712 by assuming the magnetic field strength of 1.3 T at the pole tip of the Nd-Fe-B magnet. The X ray having the energy of 30 - 800 eV can be produced by changing the gap width from 20 to 26.7 mm and the electron beam energy of 0.3 - 1.7 GeV.

3.3 Magnetic Field on the Beam Axis

The calculated magnetic fields are shown in Fig. 2, and the relations between the gap width, the phase shift and the field are shown in Fig. 3. The maximum magnetic field is 0.245 T. For any gap width, the circularly polarized X ray is obtained at the phase shift is around 11 mm. To keep the polarization during the energy scanning, both the gap width and the phase have to be simultaneously changed as shown by an arrow in the figure.

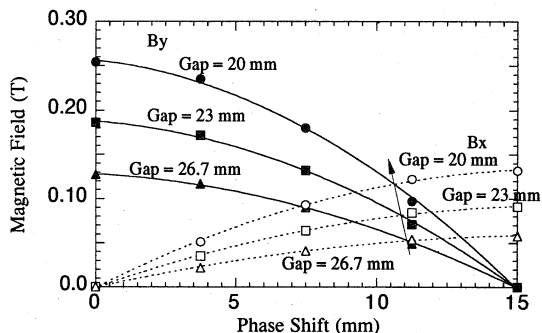

Fig. 3 Maximum magnetic field as a function of the phase shift.

3.4 Photon Flux

The photon flux is calculated for both case of the linear polarization ($K=0.712$) and the circular polarization ($K_x=K_y=0.328$), and they are shown in Fig. 4. The photon fluxes are larger than 10^{15} photons/(s 0.1%b.w.) for both cases in the whole energy range. The requirement from the experiment will be completely satisfied. The flux for the case of the linear polarization is about three times larger than that for circular polarization because of larger magnetic field.

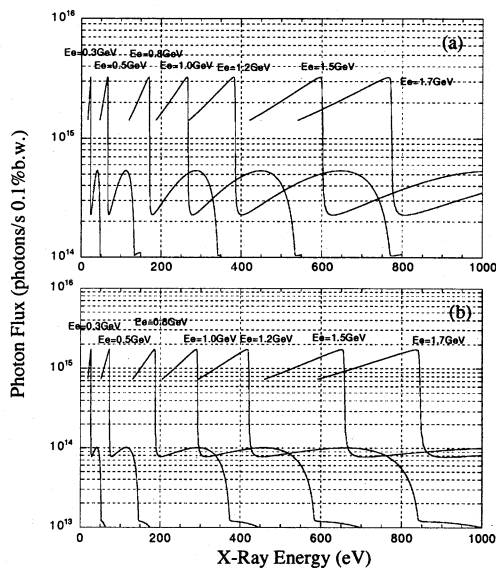

Fig. 4 Photon flux for the linearly polarized X ray (a) and the circularly polarized X ray (b).

3.5 Mechanical Structure

Whole system of the undulator having the total length of 6.24 m is divided into two undulator units because it is too long to construct a 6-m undulator with high accuracy. Both are exactly the same and they are coupled in tandem with the distance of 60 mm. Figure 5 shows the front view and the side view of the unit of the undulator. It

consists of the magnet array, array holders, support stands, a vacuum tube, correction magnets, valves, and gap and phase driving system. In one unit, the length of the magnet array is 2400 mm and the number of periods is 80. Total weight is about 7.5 t per unit.

The vacuum tube inserted in between the magnets has special form because not only the low emittance electron

beam but also the heavy ion beam are stored in the DSR depending on the operation mode [4]. The tube has three rooms; those are for the low emittance electron beam, for the heavy ion beam and for the NEG pump as shown in Fig. 6. When the DSR is used as the heavy ion storage ring, the tube is moved without breaking vacuum after expanding the gap width to 300 mm.

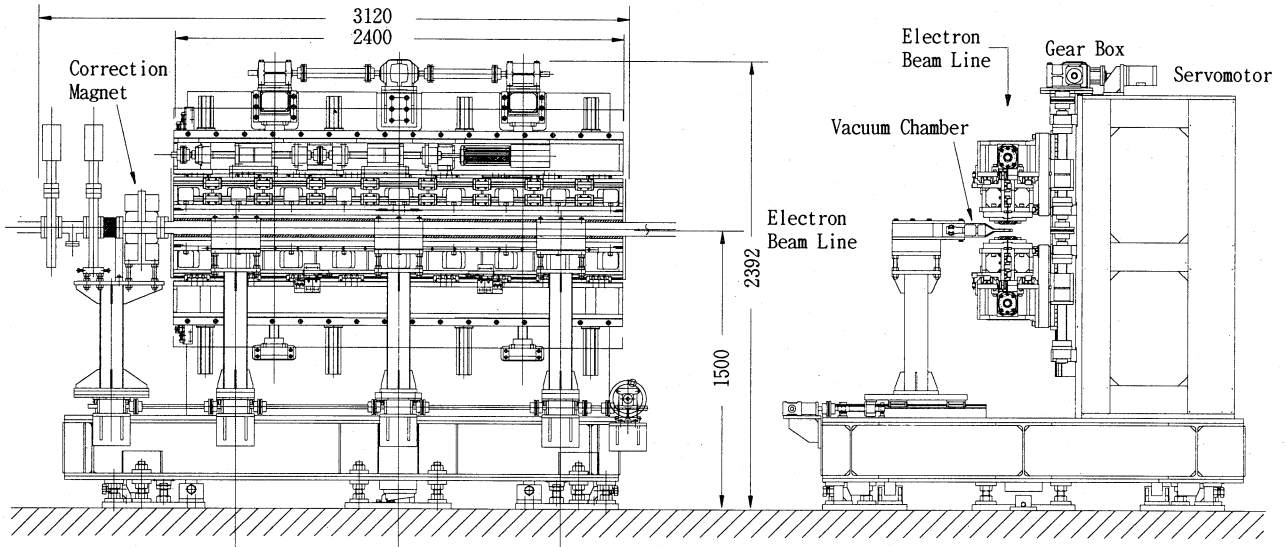

Fig. 5 The Apple-II undulator unit.

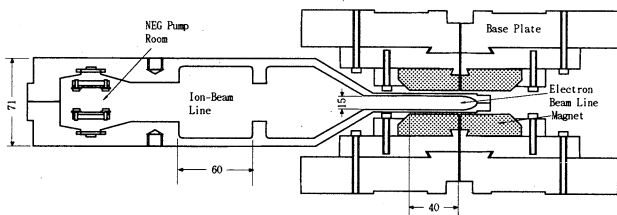

Fig. 6 Cross section of the vacuum tube inserted in between the magnets.

3.6 Gap and Phase Driver

The gap driving system consists of a servomotor, two decelerator, a gear box, four linear guide, position sensors and interlock system. The magnetic force acting on a magnet array is calculated to be about 1 t in the horizontal direction, 0.2 t in the vertical direction and 0.8 t in the beam direction. The accuracy of the gap driving can be achieved to be less than 5 μm that comes from the

requirement of the minimum X-ray energy scanning step of 0.1 eV. The driving system has a feed back system from the position sensors, and it can keep the gap width within 3 μm . The phase driver has the same kind of the system.

References

- [1] Y. Yano et al., Proc. 5th European Particle Accelerator Conf., p. 536 (1996).
- [2] T. Katayama et al., Proc. 5th European Particle Accelerator Conf., p. 563 (1996).
- [3] M. Wakasugi et al., Proc. 5th European Particle Accelerator Conf., p. 611 (1996).
- [4] N. Inabe et al., Proc. 5th European Particle Accelerator Conf., p. 926 (1996).
- [5] S. Sasaki et al., Nucl. Instrum. Meth. A331, 763 (1993).