

## An energy upgrade of RIKEN Heavy Ion Linac

Eiji Ikezawa, Masayuki Kase, Nobuhisa Fukunishi, Masaki Fujimaki, Osamu Kamigaito, Shigeo Kohara, Toshimitsu Aihara,\* Tomonori Ohki,\* Hiroo Hasebe,\* Hiromoto Yamauchi,\* Akito Uchiyama,\* Yoshitomo Uwamino, Akira Goto, and Yasushige Yano  
The Institute of Physical and Chemical Research (RIKEN),  
2-1, Hirosawa, Wako-shi, Saitama 351-0198 Japan  
\* SHI Accelerator Service, Ltd.

### 1 INTRODUCTION

The RIKEN heavy ion linac (RILAC) started to supply beams for experiments in 1981 [1] and to inject them to the RIKEN ring cyclotron (RRC) in December 1986. The maximum beam energy of the RILAC is 4 MeV/nucleon. A PIG ion source installed in the 450 kV Cockcroft-Walton injector was replaced with an 8-GHz ECR ion source (NEOMAFIOS) in fall of 1990 [2]. A new system consisting of a variable-frequency folded-coaxial RFQ linac [3] and an 18-GHz ECR ion source [4] was installed as the second pre-injector to the RILAC in 1996. The both pre-injectors had been used depending on requirement of experiments since January 1997.

In the RIKEN RI-beam factory (RIBF) project, a Charge-State Multiplier (CSM) system has been proposed in order to increase the charge state of the ions that are injected into the RRC [5]. In 1999, the first unit of the CSM, consisting of two acceleration cavities and one deceleration cavity, has been constructed [6]. In 2000, in a collaboration between RIKEN and the Center of Nuclear Science (CNS) of Tokyo University, the rest of four acceleration cavities were constructed [7]. These six cavities were installed just after the RILAC as a booster of the RILAC in summer of 2000. The maximum beam energy, which is boosted by the CSM, is 5.8 MeV/nucleon. The maximum beam intensity assumed is  $10 \text{ p}\mu\text{A}$ .

To utilize the beams accelerated by the RILAC or the RILAC + CSM for various experiments, the beam transport system of the RILAC facility has been replaced to the new one. One of the most important experiments proposed here is the search of super-heavy elements via a sub-barrier fusion reaction. It has been decided that, for the next two years until the first phase of RIBF will start, a stand-alone use of the RILAC using the booster cavities of the CSM is planned for the research of super-heavy elements.

### 2 BOOSTER

The six booster cavities and one deceleration cavity have been installed just after the RILAC as shown in Fig. 1. The first two booster cavities (CSM A1, A2) and the last

deceleration cavity (CSM D1), which form the first unit of the CSM, were fabricated with a full specification. They are of variable-frequency type, being tunable from 36 to 76.4 MHz. The other four booster cavities (CSM A3~A6) were made without a frequency tuner to save a cost. They are operated at a fixed frequency of 75.5 MHz. This frequency was selected to set the maximum energy at 5.8 MeV/nucleon which is required by the research of super-heavy elements.

The operational radio-frequencies are twice as that of the RILAC to double the acceleration gradient. The required gap voltages are approximately 500 kV. The total voltage-gain of the booster cavity is 16 MV, which is the same as that of the RILAC. The ions which have a mass-to-charge ratio of less than 5.6 are accelerated up to 5.8 MeV/nucleon.

Each cavity is equipped with a turbomolecular pump of 520 l/s and a cryogenic pump of 4000 l/s. The vacuum stays in the range of  $0.5\text{-}1.0 \times 10^{-7}$  Torr in the cw-mode operation.

High-power tests of the cavities have been performed since September 2000 [8].

### 3 NEW BEAM TRANSPORT SYSTEM

The beam transport system of the RILAC was modified in order to insert the CSM system between the RILAC and the RRC. The new beam transport system is illustrated in Fig. 1. It has one main line and six branches. The main line transfers ions from the RILAC to the RRC via the CSM. The bending magnet BM90 separates the desired charge state from others by utilizing the difference in magnetic rigidity. Four successive dipole magnets (SW, BA-A, BA-B and BM85) bend the beams further. The total bending angle is 355 degrees. This structure produces a space for the decelerator section of the CSM which will be installed in the future. The ions are transferred to the RRC using the existing beam line. The section from the charge stripper to the decelerator is designed to be achromatic and isochronous like a ring cyclotron. These features are effective to avoid complicated coupling of the longitudinal motion driven by the CSM and the horizontal motion caused by the beam line magnets.

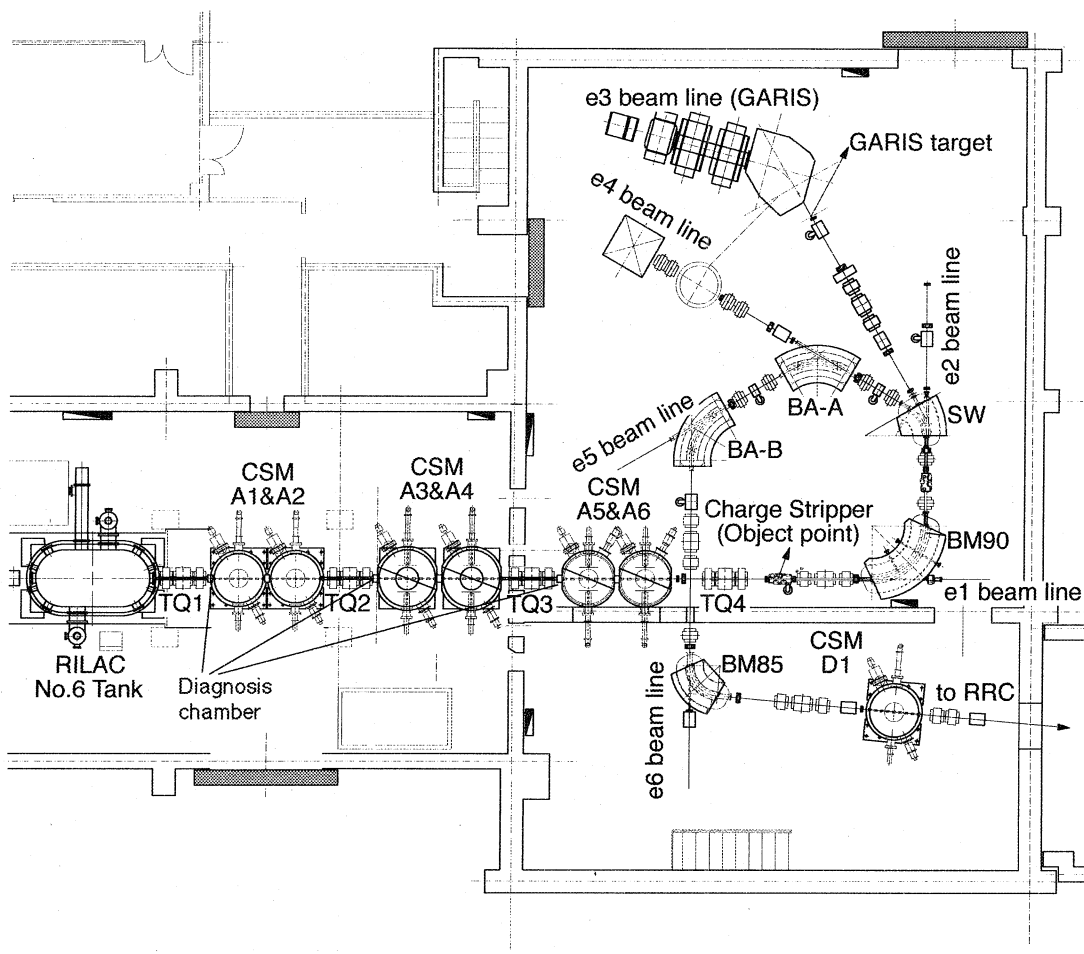

Figure 1. The new beam transport system in the RILAC facility is illustrated. The CSM consists of six booster cavities (A1~A6), a charge stripper and a decelerator (D1). The beam transport system has one trunk line from the RILAC to the RRC and six branches for experiments. Four sets of quadrupole magnets (TQ1~TQ4) are newly fabricated.

The six branches (beam line e1 ~ e6) aim to provide beams accelerated by the RILAC or the RILAC + CSM for use in several experiments. We plan to use the e3 beam line for the search for super-heavy elements, the e6 beam line for the accelerator mass spectrometer, and the e5 beam line to develop a new charge stripper system, and the e4 beam line is exclusively used by the CNS of Tokyo University.

The maximum beam energy is now 5.8 MeV/nucleon whereas that of the RILAC is limited to be 4 MeV/nucleon. It enables us to conduct the search for super-heavy elements via a sub-barrier fusion reaction using a gas-filled recoil isotope separator (GARIS) installed in the e3 beam line. The maximum magnetic rigidity is limited to 2.1 Tm for the beam lines e2 and e3 and 1.2 Tm for beam lines e4, e5 and e6. In contrast, the maximum magnetic rigidity of the beams accelerated by the CSM is 4 Tm. Beam line e1 accepts all the beams because there is no insertion of bending magnets.

The new beam transport system is mainly composed of the devices used in the old beam lines. What we have newly constructed are three dipole magnets, four quadrupole triplets, power supplies for the quadrupole magnets and

several beam-monitoring devices. For the new dipole magnets, we use existing power supplies. The specifications of the dipole magnets are summarized in Table 1. We should mention that the tape coil technique is used for these magnets to reduce power consumption and space. These dipole magnets were fabricated by TOKIN.

The construction of the new beam transport system has finished last May.

Type	BM90	SW	BM85	
Deflection angle (deg.)	90	30	60	24
Curvature radius (m)	1.4	1.6	0.8	0.8
Maximum field (T)	1.50	1.50	1.50	1.50
Pole gap (mm)	60	60	60	60
Pole face rotation (deg.)	25/25	0/0	0/30	25/25
Total coil windings	432	432	432	432
Maximum current (A)	200	200	200	200
Maximum voltage (V)	65	37	42	42

Table 1 Specifications of newly constructed dipole magnets.

## 4 BEAM DIAGNOSIS

A beam diagnosis device for the CSM was developed. Figure 1 and 2 show the diagnosis chamber and the cutting view from the diagnosis chamber, respectively. The beam diagnosis chamber was designed to be very compact because the maximum space for the chamber was limited to 130 mm. This diagnosis chamber contains the phase probe, the profile monitor and the Faraday cup and also has the special gate valve. This gate valves close the both beam entrances to the vacuum chamber by one movement. Therefore, the profile monitor and the Faraday cup can be maintained without breaking the vacuum for the beam line. The phase probe is installed in the section of the short beam pipe which connects the CSM cavity with the diagnosis chamber. The phase probe has a ring electrode with a diameter of 40 mm and a thickness of 8 mm, and its signal line exits the chamber through the vacuum-sealed SMA connector whose ground side is floated.

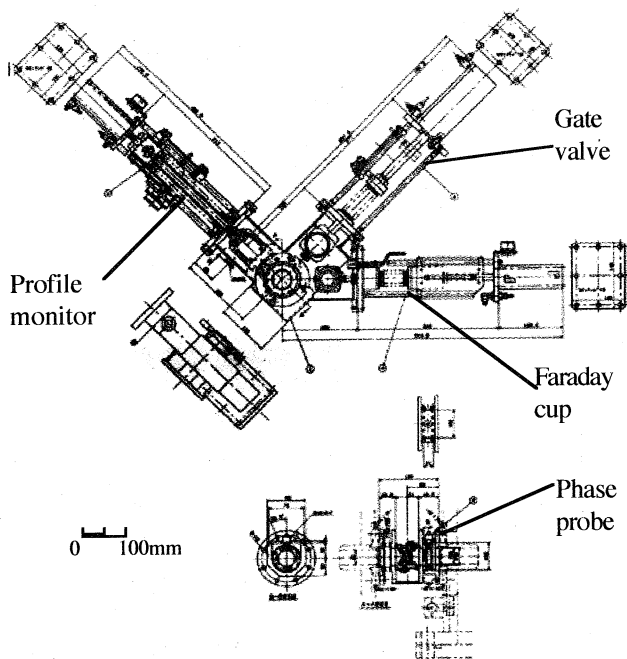

Figure 2. The cutting view from the diagnosis chamber.

## 5 WATERCOOLING SYSTEM

A new deionizer watercooling system was installed in September 2000. The cooling capacity is 1.3 MW. This system has been used for the CSM, for four quadrupole triplet magnets of the CSM section and for the power supplies of the quadrupole triplet magnets. The total water flow is 4300 l/min. The total water flow per cavity of the CSM is 600 l/min.

## 6 RADIATION PROTECTION

Because the maximum beam energy of the CSM is beyond the Coulomb barrier, the local radiation shield is added around the bending magnet BM90 and the GARIS assuming a 10 pμA primary beam stops there.

The radiation safety control system of the RILAC facility have been replaced with a new one, which consists of a radiation monitoring system, an access control system and a beam interlock system.

## 7 BEAM ACCELERATION TEST

We started test operations of the CSM in May 2001. We accelerated Carbon and Argon beams using the CSM. For <sup>40</sup>Ar beams, we obtained 5.8 MeV/nucleon with an intensity of 4.8 pμA. The beam energy was determined by the analyzer magnet BM90 in which a NMR probe measured magnetic flux density precisely. The maximum transmission efficiency through the CSM is 98 % for an Ar<sup>11+</sup> beam. The maximum transmission efficiency from the ion source to the end of the CSM is however 62 % in this case, because the typical transmission efficiency from the ion source to the end of the RILAC is 50 to 70 %.

We have restarted beam services to the RRC experiments without acceleration by the CSM. We also made preliminary beam tests for the GARIS experiment. For both cases, we did not detect sizable beam loss.

## REFERENCES

- [1] M. Odera et al.: "Variable Frequency Heavy-Ion Linac, RILAC", Nucl. Instr. Meth., 227 187 (1984)
- [2] E. Ikezawa et al.: "ECR Ion Source for RIKEN Heavy Ion Linac", The 8th Sympo. on Accel. Sci. and Tech., Saitama, Japan (1991) 73
- [3] O. Kamigaito et al.: "Recent Developments of the Folded-Coaxial RFQ for the RIKEN Heavy-ion Linac", Proceedings of the XIX International LINAC Conference, Chicago, 1998, p.780.
- [4] T. Nakagawa et al.: "Recent Progress of RIKEN 18 GHz ECRIS", 1997 Particle Accelerator Conference, 1997, Vancouver (1997).
- [5] Y. Yano et al.: Proc. 1997 Particle Accelerator Conf. (PAC97), Vancouver, Canada, May 1997, p.930(1997)
- [6] O. Kamigaito et al.: Proc. 12<sup>th</sup> Symp. on Accelerator Science and Technology, October 27-29, 1999, p. 233.
- [7] O. Kamigaito et al.: RIKEN Accel. Prog. Rep. 34, p322 (2001)
- [8] O. Kamigaito et al.: "RF Cavities of the RIKEN Charge-State Multiplier", in this Proceedings.